

ARMY
AIR FORCE
NAVY

TM 11-5895-1195-10
TO 31R2-2URC-71
EE 150-NA-OPI-010/
E120-URC100.1.4

OPERATOR'S MANUAL

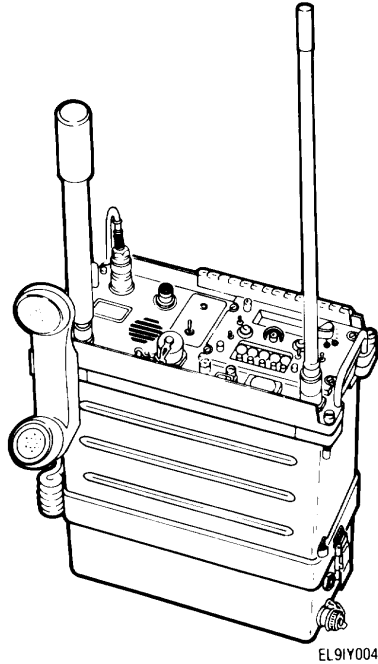

**EQUIPMENT
DESCRIPTION**
Page 1-6

**OPERATOR'S
CONTROLS**
Page 2-1

PMCS
Page 2-10

OPERATION
Page 2-13

RADIO SETS
AN/URC-100
(NSN 5820-01-112-0176)
AN/URC-101
(NSN 5820-01-112-0177)
AND AN/URC-104
(NSN 5820-01-131-5674)

DEPARTMENT OF THE ARMY, THE AIR FORCE, AND THE NAVY

12 JULY 1984

WARNING

**DANGEROUS VOLTAGES EXIST IN
THIS EQUIPMENT**

- Lethal voltages are exposed when battery inset is removed and power supply ac power cable is connected to ac outlet. Failure to disconnect the power cable from the outlet may result in injury or death.
- Caution should be exercised when servicing the radio and operating the transmitter with the antennas. The RF field radiated from the tip of the antenna could cause facial burns or eye damage if the antenna is held closer than 4 inches for extended periods while transmitting. When operating in the UHF FM HIGH power (20 watt) mode, the minimum distance should be 16 inches.

Technical Manual
No. 11-5895-1195-10
Technical Order
TO 31R2-2URC-71
Technical Manual
EE 150-NA-OPI-101/
E120-URC100.1.4

DEPARTMENTS OF THE ARMY,
THE AIR FORCE AND THE NAVY

Washington, DC, 12 July 1984

OPERATORS MANUAL
RADIO SETS
AN/URC-100 (NSN 5820-01-112-0176)
AN/URC-101 (NSN 5820-01-112-0177)
AND
AN/URC-104 (NSN 5820-01-131-5674)

REPORTING ERRORS AND RECOMMENDING IMPROVEMENTS

You can help improve this manual. If you find any mistakes or if you know of a way to improve the procedures, please let us know. Mail your letter or DA Form 2028 (Recommended Changes to Publications and Blank Forms) direct to: Commander, US Army Communications-Electronics Command and Fort Monmouth, ATTN: DRSEL-ME-MP, Fort Monmouth, New Jersey 07703. For Air Force, submit AFTO Form 22 (Technical Order System Publication Improvement Report and Reply) in accordance with paragraph 6-5, Section VI, T.O. 00-5-1. Forward direct to prime ALC/MST. For Navy, mail comments to the Commander, Naval Electronics Systems Command, ATTN: ELEX 8122, Washington, DC 20360. In either case, a reply will be furnished direct to you.

		Page
		HOW TO USE THIS MANUAL.....iii
CHAPTER	1	INTRODUCTION 1-1
Section	I	General Information 1-1
	II	Equipment Description 1-6
	III	Technical Principles of Operation..... 1-12
CHAPTER	2	OPERATING INSTRUCTIONS 2-1
Section	I	Description and Use of Operator Controls and Indicators 2-1
	II	Preventive Maintenance Checks and Services (PMCS) 2-10
	III	Operation Under Usual Conditions..... 2-13
CHAPTER	3	MAINTENANCE INSTRUCTIONS 3-1
Section	I	Troubleshooting Procedures 3-1
	II	Maintenance Procedures 3-11
APPENDIX	A	REFERENCES A-1
	B	COMPONENTS OF END ITEM LIST B-1
Section	I	Introduction B-1
	II	Components of End Item B-5
	III	Basic Issue Items B-8
APPENDIX	C	ADDITIONAL AUTHORIZATION LIST (NOT APPLICABLE)..... C-1
	D	EXPENDABLE SUPPLIES AND MATERIALS LIST D-1
Section	I	Introduction D-1
	II	Expendable Supplies and Materials List D-3

HOW TO USE THIS MANUAL

- This manual describes the typical arrangements of the AN/URC-100, AN/URC-101 and AN/URC-104 Radio Sets.
- When using this manual, remember to observe all cautions and warnings and follow the appropriate procedures for the equipment in use.
- This manual provides all the necessary information needed to operate the AN/URC-100, AN/URC-101, and AN/URC-104 units.

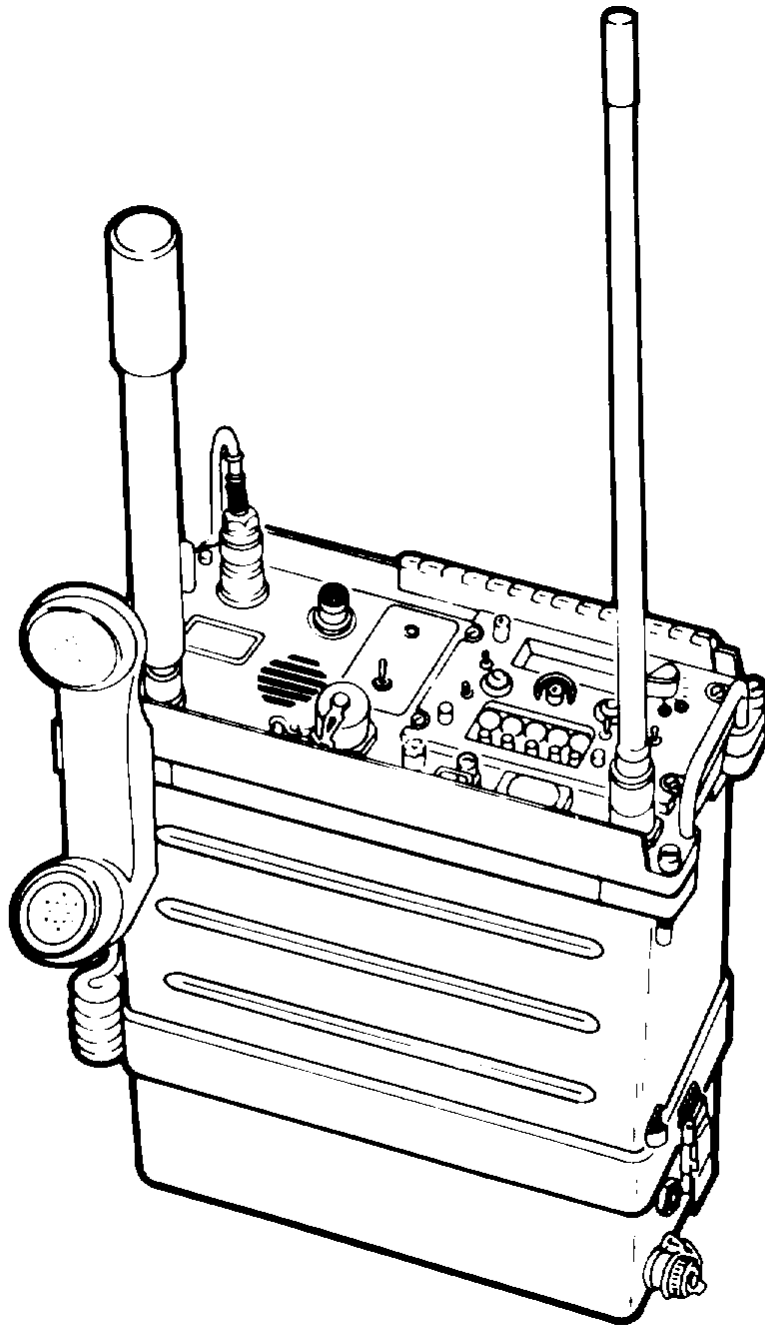

EL91Y004

Figure 1-1. AN/URC-100, AN/URC-101 and AN/URC-104 Radio Sets

**CHAPTER 1
INTRODUCTION**

Section I. GENERAL INFORMATION

Subject	Para.	Page
Scope	1-1	1-1
Maintenance Forms, Records and Reports	1-2	1-2
Hand Receipt (-HR).....	1-3	1-2
Consolidated Index of Army Publica- tions and Blank Forms.....	1-4	1-2
Reporting Equipment Improvement Recommendations (EIR's).....	1-5	1-3
Warranty Information	1-6	1-3
Nomenclature Cross-Reference List.....	1-7	1-4
List of Abbreviations.....	1-8	1-4
Glossary.....	1-9	1-5

1-1. Scope

This manual provides the operator-level operating and maintenance instructions for Radio Sets, Models AN/ URC-1 00, AN/URC-1 01, and AN/URC-1 04, hereinafter referred to by their actual nomenclature or the term Radio Set.

The Radio Sets shown in Figure 1-1 are multichannel AM/FM radio sets for use in either secured or unsecured UHF or VHF voice communications systems. The Radio Sets can be configured for relay-type operation to extend the range

1-1 Scope (cont)

beyond line-of-sight. The various operating configurations are described in Chapter 2 of this manual.

1-2. Maintenance Forms, Records and Reports

Department of the Army forms and procedures for equipment maintenance will be those prescribed by DA Pam 738-750 as contained in Maintenance Management Update.

1-3. Hand Receipt (-HR) Manuals

This manual has a companion document with a TM number followed by "-HR" (which stands for Hand Receipt). The TM11-5895-1195-1 0-HR consists of pre- printed hand receipts (DA Form 2062) that list end item related equipment (i.e., COEI, BII and AAL) you must account for. As an aid to property accountability, additional -HR manuals may be requisitioned from The US Army Adjutant General Publications Center, Baltimore, MD, in accordance with the procedures in Chapter 3, AR 310-2 and DA Pam 310-10-2.

1-4. Consolidated Index of Army Publications and Blank Forms

Refer to the latest issue of DA Pam 310-1 to determine whether there are new editions, changes or additional publications pertaining to the equipment.

1-5. Reporting Equipment Improvement Recommendations (EIR's)

If your equipment needs improvement, let us know. Send us an EIR. You the user, are the only one who can tell us what you don't like about your equipment. Let us know why you don't like the design. Tell us why a procedure is hard to perform.

- Army - Put your recommendation or complaint on a SF 368 (Quality Deficiency Report) and mail it to: Commander, US Army Communications- Electronics Command and Fort Monmouth, ATTN: DRSEL-ME-MP, Fort Monmouth, NJ 07703.
- Air Force - Submit your EIR's in accordance with AFR 900-4.
- Navy - Submit your EIR's through your local beneficial suggestion program. We will send you a reply.

1-6. Warranty Information

The Radio Sets are warranted by Motorola Inc., for a period of 12 months. The warranty starts on the date found in block 23, DA Form 2408-9, in the logbook. Report all defects in material or workmanship to your supervisor, who will take appropriate action through your organizational maintenance shop.

1-7. Nomenclature Cross-Reference List

Table 1-1 lists the nomenclature that is different from the official nomenclature.

Table 1-1. Nomenclature Cross Reference List

Common Name	Official Nomenclature
Radio Set	Radio Set AN/URC-100
Radio Set	Radio Set AN/URC-101
Radio Set	Radio Set AN/URC-104
Receiver/Transmitter or R/T	(none)
Receiver/Transmitter or R/T	(none)
Receiver/Transmitter or R/T	(none)
Power Supply & Battery Pack Model PTMG-120	Power Supply (To be assigned)
VHF Antenna AN/URC-100 and AN/URC-101	Antenna (To be assigned)
VHF Antenna AN/URC-104	Antenna (To be assigned)
UHF Antenna	Antenna (To be assigned)
Handset Model PTHS110	Handset H-189/GR

1-8. List of Abbreviations

Table 1-2 contains special or unique abbreviations, acronyms or descriptions (signs or symbols) that are not contained in, nor in conflict with MIL-STD-12. Each abbreviation is defined upon its first usage within each chapter.

Table 1-2. List of Abbreviations

Abbreviation	Meaning
AAL	Additional authorization list
BII	Basic issue items
COEI	Components of end item
CT	Cipher text
dB	Decibel
Hz	Hertz
kHz	KiloHertz
MAN	Manual
MHz	MegaHertz
mW	Milliwatts
PS	Power supply
PT	Plain text
PTT	Push-to-talk
RCV	Receive
RCU	Remote control unit
SATCOM	Satellite communications
SPKR	Speaker
W	Watts

1-9. Glossary

Special or unusual terms used in this manual and their definitions are listed in the following glossary.

Table 1-3. Glossary of Special Terms

Term	Definition
COMSEC	Secured communications either by encryption or other coding devices.
CT	Cipher Text communications that are secured by a coding device, such as KY-57, etc.
PT	Plain Text communications that are unsecured, such as normal (unscrambled) voice communications.
SATCOM	Communications that are conducted via a satellite communications link.

Section II. EQUIPMENT DESCRIPTION

Subject	Para.	Page
Equipment Characteristics, Capabilities and Features	1-10	1-6
Location and Description of Major Components.....	1-11	1-8
Differences Between Models	1-12	1-8
Equipment Data	1-13	1-11

<p>1-10. Equipment Characteristics, Capabilities and Features</p>
--

The Radio Set's characteristics, capabilities, features and their differences for each model are listed in Table 1-4.

Table 1-4. Equipment Characteristics, Capabilities and Features

Characteristic, Capability and/or Feature	AN/URC-100	AN/URC-101	AN/URC-104
Half duplex operation	X	X	X
50-ohm VHF test jack			X
All weather operation	X	X	X
7000 UHF frequencies	X	X	X
1360 VHF frequencies	X	X	
2320 VHF frequencies			X

Table 1-4. Equipment Characteristics Capabilities and Features (cont)

Characteristic, Capability and/or Feature	AN/URC-100	AN/URC-101	AN/URC-104
25 kHz channel spacing	X	X	X
Emergency beacon	X	X	X
Channel scanning	X	X	X
AM and FM modulation capability in UHF	X	X	X
AM and FM modulation capability in VHF	X	X	
FM modulation capability in VHF			X
Plain and cipher text capability	X	X	X
Internal or handset speaker	X	X	X
VHF 150 Hz tone squelch transmitted			X
Remote operation capability	X	X	X
6 nonvolatile memory and 2 guard preset frequency storage locations	X	X	X
Retransmit capability	X	X	X
Rechargeable battery pack	X	X	X
Can be used for backpack vehicular and aircraft applications	X	X	X

*Cipher text operation requires external encryptor/decryptor

1-11. Location and Description of Major Components

- ① Handset
- ② UHF Antenna
- ③ VHF Antenna
- ④ Receiver/Transmitter
- ⑤ Power Supply

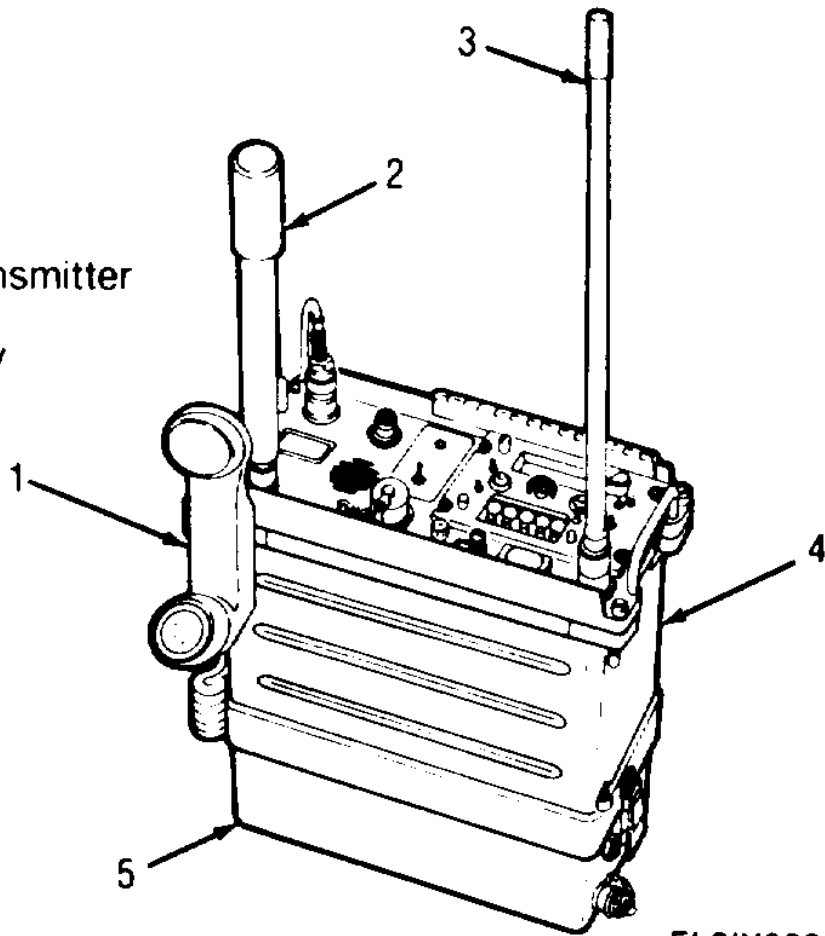

EL91Y002

1-12. Difference Between Models

There are no significant operational differences between the Radio Set models except those noted in Table 1-4. The operating frequencies may differ; however, this has no effect upon the operator controls and indicators. Equipment operating parameters are noted in Table 1-5.

Table 1-5. Operating Parameters

Function	Characteristics	AN/URC-100	AN/URC-101	AN/URC-104
Frequency				
VHF range	30.000 to 87.975 MHz			X
VHF range	116.000 to 149.975 MHz	X	X	
UHF range	225.000 to 399.975 MHz	X	X	X
Tuning increments	25 kHz	X	X	X
Preset channels	8 total of which 6 are operational channels and 2 are guard channels	X	X	X
Operating modes	Plain text or cipher text when connected to KY-57, KY-58, or KY-65	X	X	X
T2/R1	Relay mode, receive on preset channel 1 and transmit on preset channel 2	X	X	X
Beacon	Emergency sweep audio	X	X	X
Modulation	AM or FM UHF or VHF AM or FM UHF FM VHF	X	X	X X
Scanning	2 guard channels and 1 operational channel	X	X	X
Transmitter				
VHF High power output	5.0W FM	X	X	X

Table 1-5. Operating Parameters (cont)

Function	Characteristics	AN/URC-100	AN/URC-101	AN/URC-104
Low power output UHF	1.5W FM	X	X	X
High power output	5.0W AM or FM 50 WAM 20 OW FM	X	X X	X X
Low power output	1.5W AM or FM 15WAM 50 WFM	X	X X	X X
Output impedance	UHF 50 Ohms (nominal at antenna jack)	X	X	X
	VHF 50 Ohms (nominal at antenna lack)	X	X	
	VHF 50 Ohms (nominal at test lack)	X		
	VHF unspecified (at antenna jack)	X		
Keying	No transmitter damage results from shorts or opens at antenna connector	X	X	X
Squelch	Adjustable from no squelch to complete audio suppression	X	X	X
Speaker audio	50 mW (nominal) power	X	X	X
Primary power	+ 28V (battery pack)	X	X	X

1-13. Equipment Data

The receiver/transmitter physical characteristics are listed in Table 1-6, and the environmental limitations are listed in Table 1-7.

Table 1-6 Physical Characteristics

Characteristics	Description	
	w o Power Supply	with Power Supply
Dimensions		
Height	5.2 inches	5.2 inches
Width	11.8 inches	11.8 inches
Depth	9.0 inches	13.2 inches
Weight	16.0 pounds	23.0 pounds

Table 1-7. Environmental Characteristics

Characteristics	Limits
Temperature operating (with sun load)	-20° C to + 55° C (includes sun load) 4° F to 131° F
Humidity (short term)	90%O
Altitude (operating)	15,000 ft

Section III. TECHNICAL PRINCIPLES OF OPERATION

Subject	Para.	Page
System Description	1-14	1-12
General Operating Features	1-15	1-15
Frequency Selection	1-16	1-16
Receive Mode	1-17	1-17
Transmit Mode	1-18	1-18
Cipher Text Receive or Transmit.....	1-19	1-19
Receiver Scanning Mode	1-20	1-19
Beacon Mode.....	1-21	1-20
Relay Mode.....	1-22	1-21

1-14. System Description

This section contains an operator-level functional description of the Radio Set. Basic items used in operation are the handset, front panel controls and indicators on the receiver/transmitter, VHF and UHF antennas, and the battery pack power supply. A block diagram of the Radio Set is shown in Figure 1-2. Figure 1-3 is an interconnection diagram showing how the handset, battery power supply and antennas are connected to the Radio Set when the equipment is ready for use.

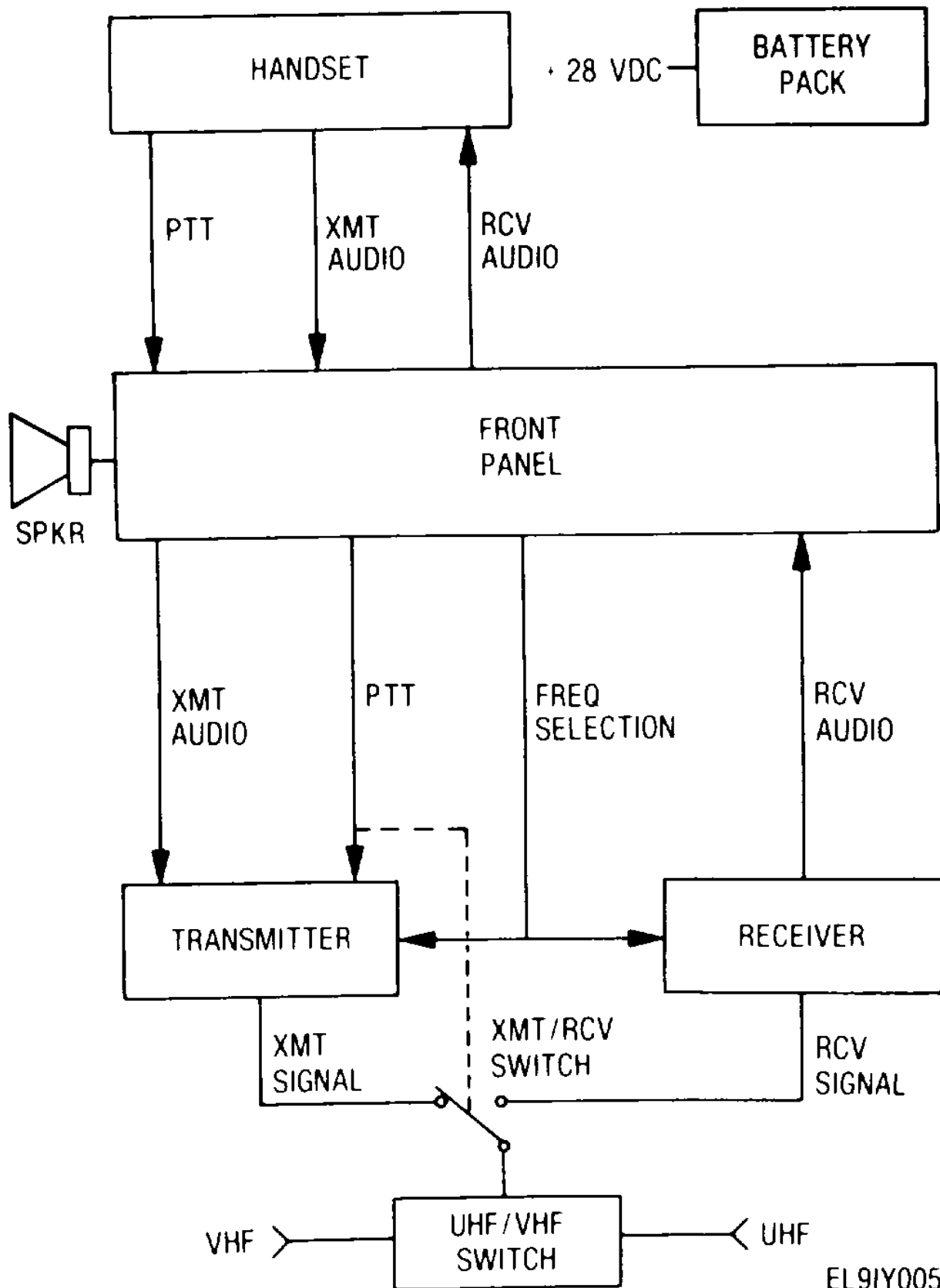

EL9IY005

Figure 1-2 Radio Set Block Diagram

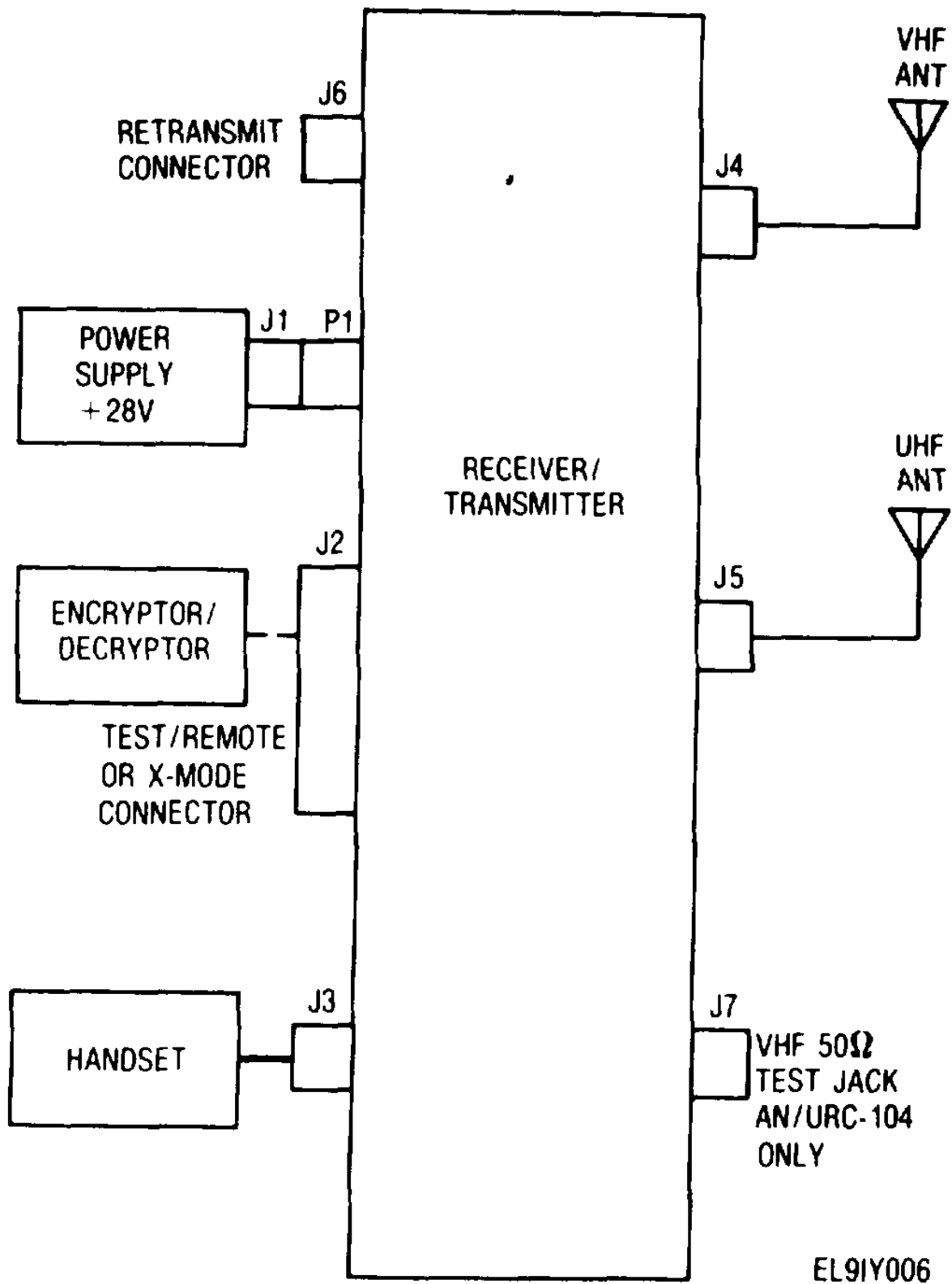

Figure 1-3. Radio Set Interconnect Diagram

1-15. General Operating Features

The receiver/transmitter used in models AN/URC-100, AN/URC-101 and AN/UBC-104 is a solid-state voice line-of-sight radio set normally used to receive and transmit plain text voice messages. They can also be used with external COMSEC equipment to transmit and receive cipher text (encrypted or scrambled) messages. The AN/URC-100 and AN/URC-101 operate in the 116 to 150 MHz VHF band and in the 225 to 400 MHz UHF band. The AN/URC-104 radio operates in the 30 to 88 MHz VHF band and in the 225 to 400 MHz UHF band. The three models are tunable across their frequency ranges in 25 kHz steps.

Operating power for the receiver/transmitter comes from the battery pack that supplies -28 V to operate the radio circuits and the front panel lamps. The display operates from +5 V which is stepped down from the +28V.

The receiver/transmitter should be operated at a 9:1 receive to transmit duty cycle. When operating at this ratio, the batteries will last 8 hours for low power (5 watts) output and 6 hours for high power (20 watts) output. Operating in the beacon mode the batteries will last 1.5 hours with low power (5 watt) output.

1-16. Frequency Selection

Selection of a receive or transmit frequency is made using the remote control unit portion of the front panel controls and indicators (fig. 1-4). The frequencies that can be selected to receive or transmit must be within the bonds of the radio being used. The table below shows those frequencies that can be used for each kind of radio.

Radio	UHF Frequencies	VHF Frequencies
AN/URC-100	225-400 MHz	116-150 MHz
AN/URC-101	225-400 MHz	116-150 MHz
AN/URC-104	225-400 MHz	30-88 MHz

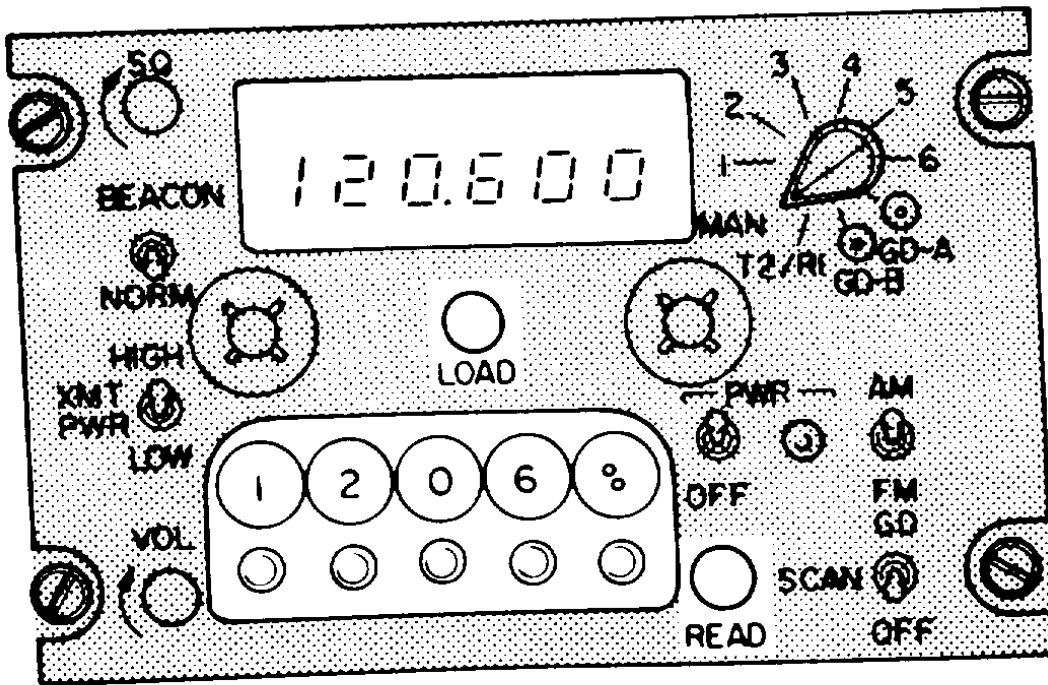

EL91Y015

Figure 1-4 RCU Controls and Indicators

Only these frequencies can be dialed into the frequency select rotary pushbuttons. If a frequency is selected that is outside the band, the radio will not transmit or receive. The frequency set into the panel switches is applied to both the transmitter and receiver circuits on the **FREQ SELECTION** line as shown in Figure 1-2. The unit has the capability of loading up to eight frequencies into the radio's memory for routine use. This allows the operator to select any one of the eight frequencies by changing the position of the front panel function selection switch. Two of the eight frequencies are guard frequencies which are monitored during the scan mode of operation described in paragraph 1-20. The frequency being transmitted or received can be viewed on a display and the panel backlighting turned on to show that frequency on a numerical display. The frequency display and panel lighting are normally off to conserve battery power.

1-17. Receive Mode

The receive mode is enabled when power is applied to the radio and the handset push-to-talk switch is not pressed. Because the switch is not pressed, the push-to-talk (PTT) line switches the unit so that incoming signals from the VHF or UHF antenna pass through the UHF/VHF switch to the **RCV SIGNAL** line. They are then demodulated and converted by the receiver circuits to form the **RCV AUDIO** signal. The receiver demodulates the incoming signals according to the settings on the front panel frequency select switches. These settings are programmed into the receiver circuits through

the FREQ SELECTION line as explained in paragraph 1-16. Received audio passes to the front panel and is routed to the internal speaker and the handset earphone. If the speaker is turned on, the incoming signal is heard through it and the handset. If the speaker is turned off, the message is routed through the RCV AUDIO line to the handset earphone where it can be heard only by the operator.

1-18. Transmit Mode

The transmit mode is enabled when power is applied to the radio and the handset PTT switch is pressed. When the switch is pressed, it generates the PTT signal. After passing through the front panel, PTT is applied to the transmitter and turns on the necessary transmit circuits. PTT also switches the transmit/receive switch to the transmit position. As soon as the push-to-talk switch is pressed, the radio is ready to transmit the operator's message. When the operator speaks into the handset microphone, the XMT AUDIO line carries the voice signal through the front panel to the XMT AUDIO line and the transmitter circuits. The message is transmitted on the frequency selected on the front panel rotary push-button switches. This frequency was programmed into the transmitter circuits by signals on the FREQ SELECTION line as explained in paragraph 1-16. Outputs from the transmitter are passed through the XMT SIGNAL line, the transmit/receive switch, and the UHF/VHF switch. Depending on whether a UHF or VHF frequency was selected, the UHF/VHF switch

1-18. Transmit Mode (cont)

routes the modulated signal to the proper antenna for transmission. The transmitter outputs either 1.5, 5, or 20 watts of power depending on the model used and various front panel switch settings. Refer to Chapter 2 for these settings

1-19. Cipher Text Receive or Transmit

Cipher text messages, also referred to as encrypted/ decrypted or scrambled" messages, may also be transmitted or received by the Radio Sets. This type of operation requires additional encryption/decryption equipments such as the KY-57, KY-58, or KY-65. The Radio Set and the encryptor/decryptor must be connected together by a cable from the TEST/REMOTE front panel connector on the AN/URC-100 or the X MODE front panel connector on the AN/URC-101 and AN/URC-104 (fig. 1-3). Operation of the radio is exactly the same in the cipher text mode as described in paragraphs 1-17 and 1-18.

1-20. Receiver Scanning Mode

In the receiver scanning mode, the front panel switches are preset so that one main receiver circuit frequency and two guard frequencies are scanned any time power is turned on and the PTT switch is not pressed. Signals entering the radio through either the UHF or VHF antenna and UHF/VHF switch are applied to the receiver circuits. These circuits

constantly monitor the frequencies set into the front panel rotary select switches which are programmed into the receiver by the **FREQ SELECTION** lines. When a transmission is detected on one of the preset frequencies, the scan stops. The receiver then monitors the detected frequency and passes the received signal through the **RCV AUDIO** line to the speaker or handset earphone. After the message is finished, the receiver again scans the selected frequencies for another incoming message.

1-21. Beacon Mode

This is an automatic mode in which the radio transmits a continuous signal tone on a frequency that is set by the operator. The operator cannot transmit or receive voice messages while in the beacon mode of operation. In this mode, the front panel **BEACON** switch is turned on, enabling the transmitter circuits through the **XMT AUDIO** line. The frequency of transmission is programmed into the transmitter by the signal on the **FREQ SELECTION** line. Placing the radio in the beacon mode automatically turns the transmit/receive switch to transmit so that the beacon tone passes to the **UHF/VHF** switch. Selection of a **UHF** or **VHF** beacon frequency automatically switches the **UHF/VHF** switch so that the signal is routed to and transmitted by the proper antenna.

1-22. Relay Mode

In the relay mode of operation, two radio sets are connected “back-to-back” so that signals received by one unit are retransmitted by the other unit on another frequency. The operating frequencies must have a minimum separation of 2 MHz. The physical separation of the R/T units should be greater than 50 feet or have a physical barrier between them.

When one radio set receives a signal, the squelch output signal from it keys the transmit of the other radio set. The RCVR AUDIO output of the receive radio set drives the PTT input of the transmit radio set, which modulates the transmitted carrier with the audio signal detected by the receive radio set.

**CHAPTER 2
OPERATING INSTRUCTIONS**

Section I. DESCRIPTION AND USE OF OPERATOR CONTROLS AND INDICATORS

Subject	Para.	Page
General.....	2-1	2-1
Introduction.....	2-2	2-1
Controls and Indicators.....	2-3	2-4

2-1. General

This section contains a functional description of the controls and indicators required to set up and operate the Radio Set.

2-2. Introduction

This section includes general information and all instructions for setting up and operating the Radio Sets in various operating configurations. These instructions should be followed to: unpack, install, select proper configuration, assemble the Radio Set, interconnect with other radios or COMSEC equipment, position front panel controls, and establish communications. As the Radio Sets are multichannel and can be configured for use in any UHF or VHF communication link, operating parameters must be established prior to beginning a mission.

These parameters are: frequencies, type of modulation, and whether the link is unsecured or secured.

- a. **Operating Frequencies.** The Radio Sets will operate in either the VHF or UHF frequency bands. The AN/URC-100 and AN/URC-101 VHF range is from 116.000 MHz to 149.975 MHz and the AN/URC-104 VHF ranges are from 30.000 MHz to 87.975 MHz. All three of the radio's UHF ranges are from 225.000 to 399.975 MHz. Eight frequencies may be selected from either or both bands and stored in function selector switch positions 1 through 6, GD A, and GD B radio channel. However, when the communication link requires different transmit and receive frequencies, the receive frequency must be assigned to channel 1 and the transmit to channel 2. These frequencies will remain in storage until changed, even with the radio power turned off.
- b. **Carrier Modulation.** All radios in the communications link must be set for the same type of modulation. All three Radio Sets will operate with AM or FM at UHF frequencies. The AN/URC-100 and AN/URC-101 radios will also operate with AM or FM at the VHF frequencies. However, the AN/URC-104 will only operate with FM at the VHF frequencies.

- c. **Secured Communications.** The radios will operate with KY-56, KY-58, or KY-65 secured communications links. However, all secured equipment and cryptographic keys must be the same. Additional interconnection cables and operating procedures are required that are not part of the Radio Set or described in this manual.
- d. **Non-Line-Of-Sight Communications.** The radios may be configured for relay or retransmit to extend the range, when obstacles are in the line of sight, or to translate frequencies to allow communications with radios operating on two different frequencies. When this configuration is used, additional cables are required to connect two units together that are not described in this manual. When satellite relays are used, the AN/URC-101 or AN/URC-104 and different antennas and cables are required. The units must be operating on specific frequency channels and with FM modulation. Also, the receive frequency must be stored in channel 1 and the transmit frequency in channel 2, as the satellite receives and transmits on different frequencies.

Additional information and equipment are required if the Radio Sets are installed in an airborne or vehicular mount or where the Remote Control Unit (RCU) is removed from the front panel and located away from the Radio Set. Instructions will be given to you on how to set up or operate in these configurations when required.

2-3. Controls and Indicators

All controls and indicators, used during the operation of the Radio Set, are located on the front panel. Controls and indicators are shown in Figure 2-1 and described in Table 2-1.

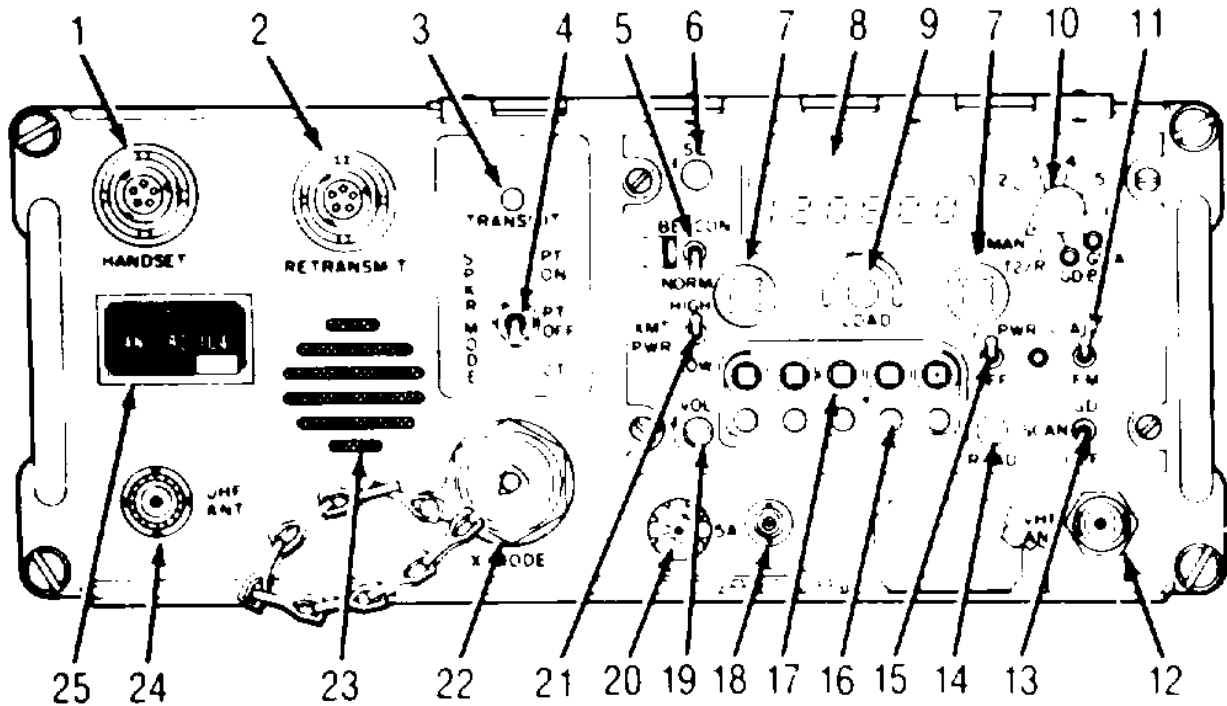

EL91Y017

Figure 2-1. Radio Set Controls and Indicators

Table 2-1. Controls and Indicators

Key	Control or Indicator	Function
1.	HANDSET (5-pin connector)	Provides connection for handset.
2.	RETRANSMIT (5-pin connector)	Provides connection to second radio set for retransmit configuration.

Table 2-1. Controls and Indicators (cont)

Key	Control or Indicator	Function
3.	TRANSMIT (LED)	Indicates that transmitter is keyed.
4.	SPKER/MODE (3-position toggle switch) PT ON	Switches the speaker on for plain text operation.
	PT OFF	Switches the speaker off for plain text operation.
	CT	Switches the receiver/transmitter to the cipher text mode of operation and turns the speaker off for cipher text operation.
5.	BEACON/NORM (2-position toggle switch) BEACON	When in BEACON position, causes transmitter to continuously output a carrier modulated with a weeper ton
	NORM	When in NORM position, allows voice to be modulated onto the transmit carrier.
6.	SQ (potentiometer)	Adjusts receiver squelch threshold sensitivity.
7.	Edge-Light (2) (screw-in lamp and holder)	Illuminates front panel when READ pushbutton is pressed.

Table 2-1. Controls and Indicators (cont)

Key	Control or Indicator	Function
8.	Frequency Display (6 seven-segment LED displays)	Displays current operating frequency when READ pushbutton is pressed.
9	LOAD (pushbutton switch)	When pressed, stores frequency which is set by the pushbutton frequency selector switches into memory location that corresponds to position of the 1 through 6, GD A, GD B function selector switch.
10	Function Selector (ten-position rotary switch)	
	MAN	Allows an alternate or random frequency to be selected manually by the frequency selector switches, for use other than those which are stored in memory.
	1 through 6, GD A and GD B	Allows selection of frequencies which are preset and stored in memory.
	T2/R1	Selects preset frequency at function selector switch position 2 for transmitting and position 1 for receiving.

Table 2-1. Controls and Indicators (cont)

Key	Control or Indicator	Function
11.	AM/FM (2-position toggle switch)	Selects either AM or FM modulation for receiving and transmitting.
12.	VHF ANT (N-type coaxial connector)	Provides connection for VHF antenna.
13.	SCAN (2-position toggle switch) GD	In receive mode, causes receiver to scan the frequencies stored in frequency positions GD A, GD b, and one of the six positions as determined by the setting of the function selector switch.
	OFF	Disables scanning feature and enables R/T to operate normally.
14.	READ (pushbutton switch)	When pressed, causes frequency in use to be displayed and the front panel to be illuminated.
15.	PWR (2-position toggle switch) up position	Applies operating power to R/T.
	OFF	Removes operating power from R/T.
	Indicator (LED green)	Illuminates when operating power is applied to R/T.

Table 2-1. Controls and Indicators (cont)

Key	Control or Indicator	Function
16.	Frequency Selector (5-separate pushbutton rotary switches)	Selects operating frequency for manual operation, and preset frequencies 1 through 6, GD A, and GD B for entry into memory when LOAD switch is pressed.
17.	Frequency Selector Indicator (part of frequency selector switch)	Displays last frequency entered from frequency selector switches.
18.	VHF (BNC coaxial connector)	Provides a 50 ohm test port for VHF (on AN/URC-104 only).
19.	VOL (potentiometer)	Adjusts receiver audio output level.
20.	FUSE 5A (5 amp, fast blow)	Provides overcurrent protection for R/T.
21.	XMT PWR (2-position toggle switch)	
	HIGH (AN/URC-100)	Sets transmitter output to 5 watts.
	LOW (AN/URC-100)	Sets transmitter output to 1.5 watts.
	HIGH (AN/URC-101)	Sets transmitter output to high power. VHF AM or FM and UHF AM-1.5 watts. UHF FM-5 watts

Table 2-1. Controls and Indicators (cont)

Key	Control or Indicator	Function
	<p>LOW (AN/URC-101)</p> <p>HIGH (AN/URC-104)</p> <p>LOW (AN/URC-104)</p>	<p>Sets transmitter output to low power. VHF AM or FM and UHF AM-1.5 watts.</p> <p>Sets transmitter output to high power VHF FM and UHF AM-5 watts. UHF FM-20 watts.</p> <p>Sets transmitter output to low power. VHF FM and UHF AM-1.5 watts. UHF FM-5 watts.</p>
22.	X MODE or TEST/REMOTE (19-pin connector)	Provides connections for test measurements, remote operations and connection to COMSEC equipment.
23.	Speaker	Provides audio output.
24.	UHF ANT (UHF-type coaxial connector)	Provides connection for UHF antenna.
25.	Identification Plate	Identifies model of Radio Set.

**Section II. PREVENTIVE MAINTENANCE
CHECKS AND SERVICES (PMCS)**

Subject	Para.	Page
General.....	2-4	2-10
PMCS Procedures.....	2-5	2-11

2-4. General

Preventive maintenance checks and services (PMCS) are scheduled maintenance performed to ensure that the Radio Set is ready for operation at all times. Inspect the Radio Set regularly and carefully, using the procedures in Table 2-2, so that you can find any defects and have them corrected.

Tightening, cleaning, and routine operator maintenance should be performed on an as-needed basis even though it is not listed in Table 2-2.

- a. Before You Operate.** Always perform your before (B) PMCS.
- b. While You Operate.** Always perform your during (D) PMCS.
- c. After You Operate.** Be sure to perform your after (A) PMCS.
- d. If Your Radio Set Fails To Operate.** Note the failure symptoms, then refer to Chapter 3. Report any deficiencies using the proper forms. See DA Pam 738-750.

2-5. PMCS Procedures

Corrective procedures for some of the faults that may be discovered during PMCS are located in Chapter 3. Faults, not listed there, are to be referred to the next higher level of maintenance.

- **Item No. Column.** This column lists the sequence number of all procedures in the chart regardless of interval. The item number in this column must be used as the entry in the "TM Number" column of DA form 2404, Equipment Inspection and Maintenance Worksheet, in recording results of PMCS.

- **Interval Column.** This column lists the interval that each PMCS procedure is performed. A dot under the "B" column indicates that the associated procedure will be performed before operation. A dot under the "d" column indicates that the procedure will be performed during operation. A dot under the "A" column indicates that the procedure will be performed after operation.

- **Item To Be Inspected Column.** This column identifies the item(s) on which the associated PMCS procedures are performed.

- **Procedures Column.** This column contains the PMCS procedures that are to be performed.

- **Equipment Is Not Ready/Available If Column.** This column describes the criteria by which the Radio Set system will be considered not ready to perform its primary function.

TABLE 2-2. PMCS Chart

B = Before, D = During, A = After

Item No.	Interval			ITEM TO BE INSPECTED Procedure	Equipment Is Not Ready Available If:
	B	D	A		
1	•			Power Supply Ensure batteries have been charged and inserted in Power Supply.	<i>Batteries need charging or replaced.</i>
2	•			Power Supply Vent Remove any dirt, mud, etc. from vent.	
3		•		Front Panel Check that TRANSMIT indicator lights when handset is keyed	<i>TRANSMIT indicator fails to light.</i>
4		•		Radio Set Operate the radio set in its expected mode (AM-FM, UHF-VHF).	<i>Radio Set fails to check out in expected mode (refer to Chapter 3).</i>

Table 2-2. PMCS Chart (Cont)

B = Before, D = During, A = After

Item No	Interval			ITEM TO BE INSPECTED Procedure	Equipment Is Not Ready/Available If:
	B	D	A		
5			•	Power Supply Remove Power Supply from R/T and recharge batteries	Batteries will not recharge.

**Section III. OPERATION UNDER USUAL
CONDITIONS**

Subject	Para	Page
Preparation for Use	2-6	2-14
Installation Options.....	2-7	2-17
Loading and Selecting Operating Frequencies	2-8	2-19
LOS Operations	2-9	2-24
Relay Operation	2-10	2-27
Satellite Operation	2-11	2-31
COMSEC Operations	2-12	2-34
Scanning Operation	2-13	2-37
Beacon Operation	2-14	2-38
Preparation for Movement.....	2-15	2-39

2-6. Preparation For Use

The Radio Sets are shipped and stored partially assembled. As the assembly varies with the installation and configuration, general assembly instructions are covered in this paragraph for each detachable part. These procedures will be referenced in the setup and operating procedures when required.

- a. Unpacking.** When unpacking the Radio Set, inspect it carefully to ensure that no components have been damaged. Check each item against the packing list to ensure that all components were received and accounted for. Retain the packing materials if reshipment is anticipated.

- b. Battery Installation.** Refer to Chapter 3 paragraph 3-7 to install or replace the batteries.
- c. Battery Pack Assembly.** To attach the battery pack power source to the radio, refer to Figure 2-2 and perform the following steps:
- (1) Ensure pull ring on battery supply is flat against top of supply.
 - (2) Position the R/T unit over the battery power supply so that the R/T and power supply connectors are aligned.
 - (3) Slowly lower R/T onto power supply.
 - (4) Gently press downward on case to seat the connectors.
 - (5) Press down on snap fastener levers until levers snap into place.

WARNING

Fasteners (4) are spring-loaded and snap into place. Use thumb or heel of hand when securing power source to the R/T catches (2) to prevent injury.

- d. Antenna Assembly.** To attach antenna to the R/T, perform the following steps:

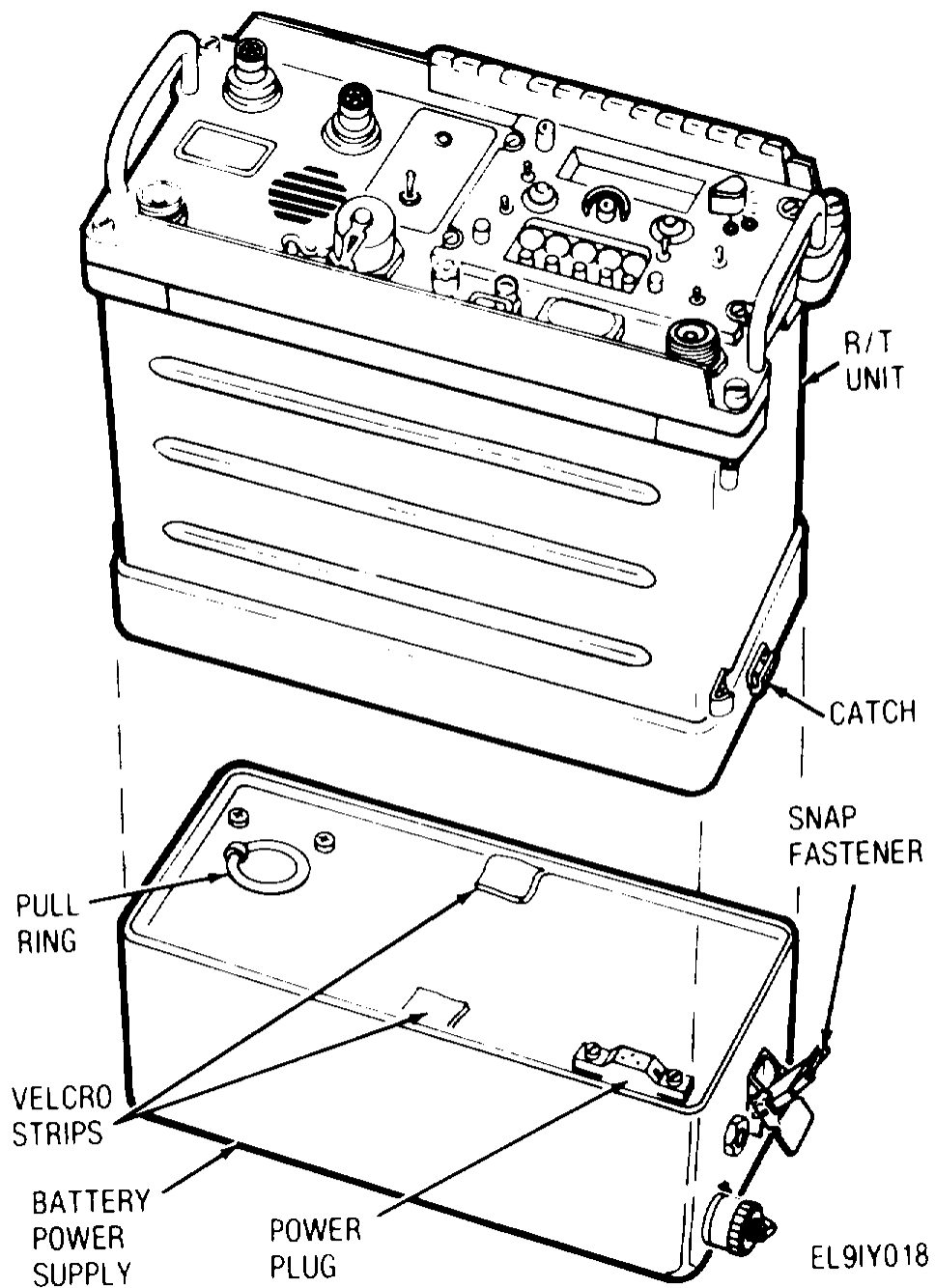

Figure 2-2. Battery Power Supply Installation

2-6. Preparation For Use (cont)

- (1) Plug each antenna into its respective connector.
- (2) Secure each antenna by tightening the retainer ring until snug.

CAUTION

Do not twist body of antenna. To do so may cause damage to either or both of the connectors.

e. Handset. To connect handset to the R/T unit, perform the following steps.

- (1) Align connector keys, then gently seat connector by pushing toward unit.
- (2) While pressing connector ring toward the panel, rotate ring clockwise approximately a quarter turn until it snaps in place.

2-7- Installation Options

The Radio Set is designed to be portable. One method of installation is to secure it to an accessory backpack carrier with tray, using heavy duty belts, as shown in Figure 2-3. Provisions are also included for securing the Radio Set to an accessory shock-mounted platform for vehicular or aircraft installation as shown in Figure 2-4.

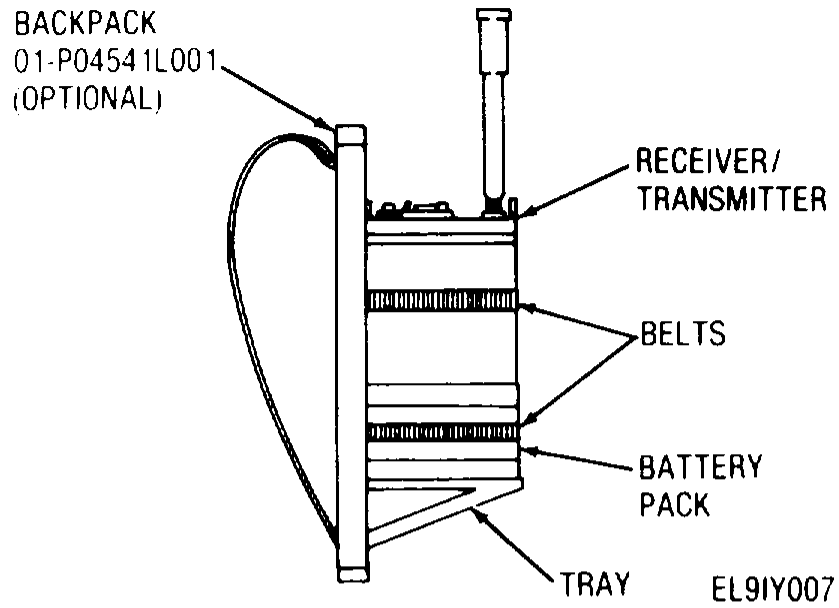

Figure 2-3. Backpack Installation

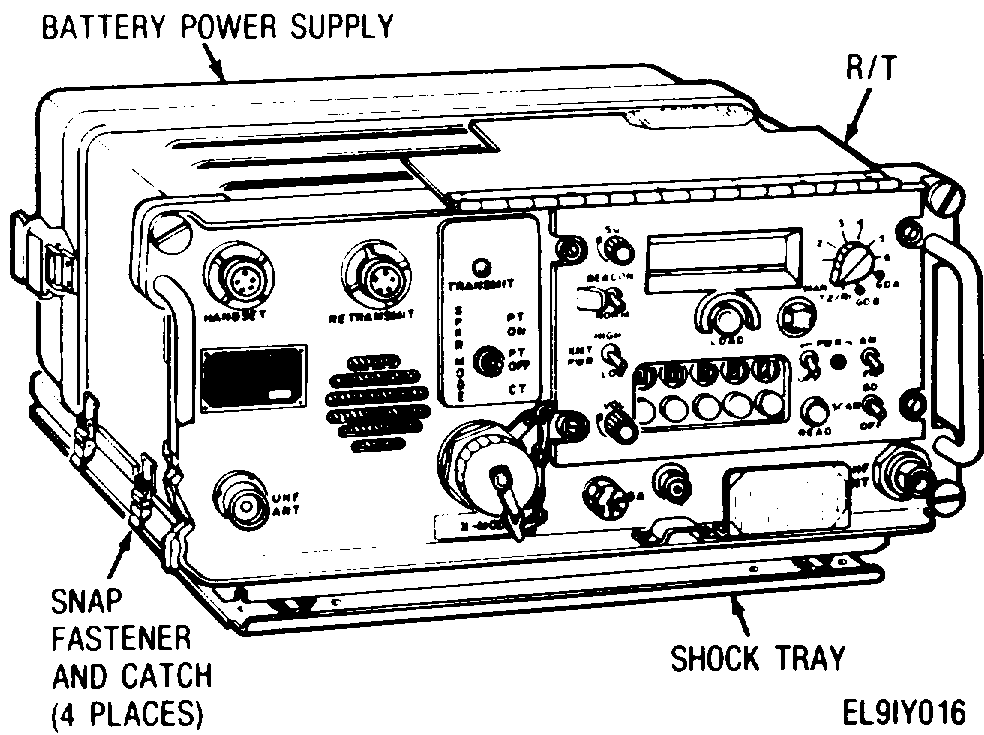

Figure 2-4. Shock-Mount Installation

2-8. Loading and Selecting Operating Frequencies I

The operating frequency must be selected prior to operating the radio. The following procedures are instructions for loading, selecting and operating with either manual or preset frequencies. The operating frequencies must be selected within the ranges shown in Table 2-3 and in increments of 0.025 MHz.

CAUTION

Do not key the transmitter while changing frequencies. To do so may damage the Radio.

NOTE

For frequencies of less than 100.000 MHz, the first digit on the left must always be a 0.

Table 2-3. Operating Frequency Ranges

Band	AN/URC-100	AN/URC-101	AN/URC-104
VHF	116.00 MHz to 149.975 MHz	116.000 MHz to 149.975 MHz	030.000 MHz to 087.975 MHz
UHF	225.000 MHz to 399.975 MHz	225.000 MHz to 399.975 MHz	225.000 MHz to 399.975 MHz

a. Manual Frequency Selection. To select and operate on a frequency other than one stored in memory, refer to Figure 2-5 and perform the following steps:

- (1) Position SCAN switch (4) to OFF.
- (2) Position PWR switch (5) to up position, then verify PWR indicator is on
- (3) Position frequency channel selector switch
(3) to MAN position.
- (4) Beginning with left-most digit, press and release left-most frequency selector push- button (7) until desired number is indicated in window above the switch (8).
- (5) Repeat step 4 for each of the remaining numbers of the selected frequency moving right to the next digit and switch for each new digit.

NOTE

The last two digits must be either 00, 25, 50, or 75 and are located on the right-most switch and indicator.

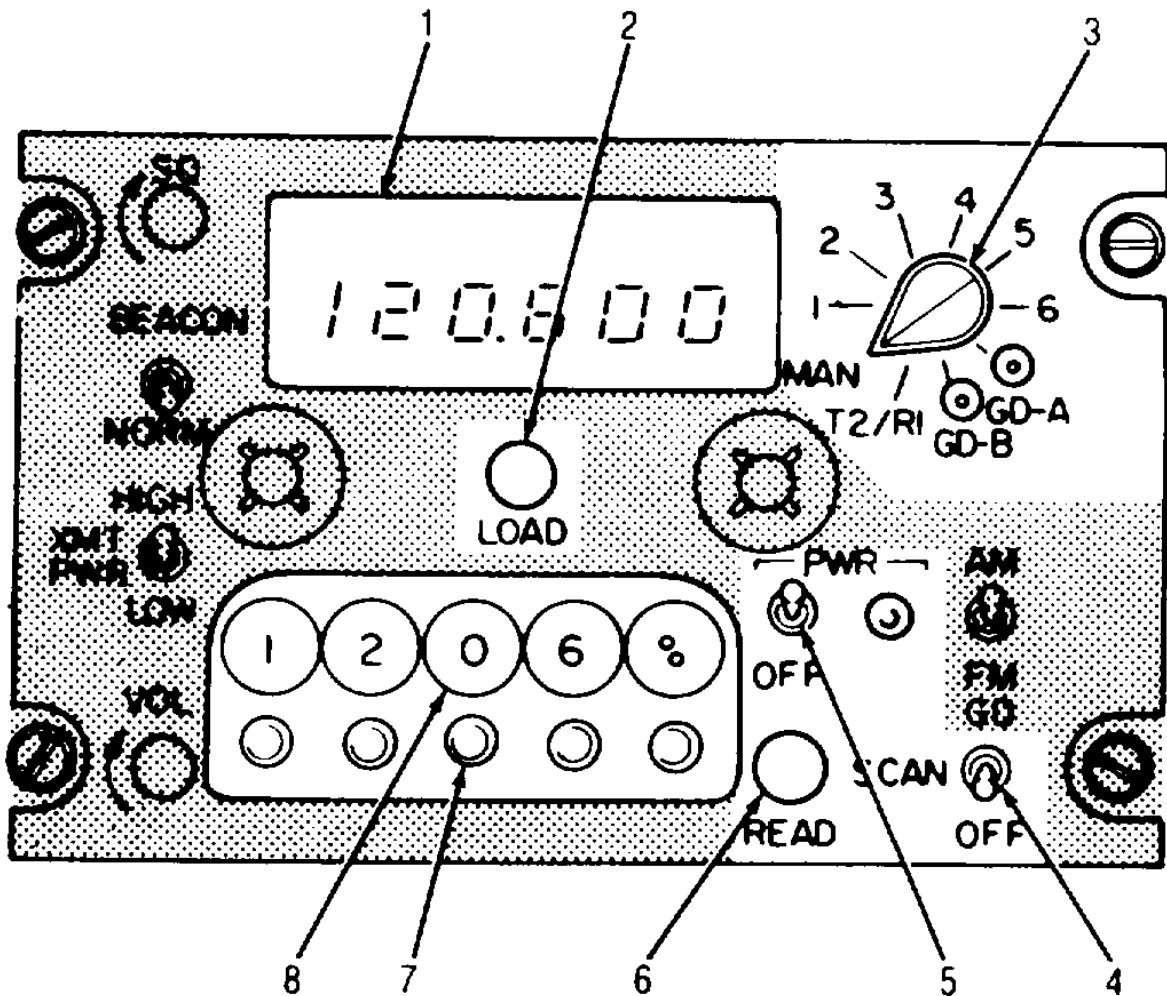

EL91Y003

Figure 2-5. Frequency Loading Controls

(6) Press and hold the READ switch (6) while ensuring selected frequency is displayed on the frequency display (1).

(7) The Radio Set will now transmit and receive on the selected frequency.

b. **Selecting Frequency for Storage.** To store six operative and two guard frequencies, refer to Figure 2-5 and perform the following steps-

- (1) Position SCAN switch (4) to OFF.
- (2) Position PWR switch (>) to up (ON) position and verify PWR indicator is on.

CAUTION

The T2/R1 position selects channel 2 when transmitting and channel 1 when receiving. Do not load frequencies while in the T2/R1 position.

- (3) Position function selector switch (3) to the channel number in which the frequency is to be stored.
- (4) Beginning with left-most digit, press and release left-most frequency selector push-button (7) until desired number is displayed in window above switch (8).
- (5) Repeat step 4 for each of the remaining numbers of the selected frequency moving right to the next digit and switch for each new digit.
- (6) Press and release LOAD push-button (2).

(7) Press and hold READ push-button (6) while ensuring the selected frequency is displayed on the frequency display (1).

(8) Position the function selector switch (3) to the next desired position and repeat steps 4 thru 7.

c. **Selecting Frequency of Operation.** The Radio Set transmit and receive frequencies are determined by the function selector switch. If channel selector switch is in MAN, the operating frequency is that which is selected on the frequency selector switches. If function selector switch is in T2/R1, the transmit frequency will be that which is stored in channel 2 and the receive frequency will be that which is stored in position 1. If function selector switch is in any one of the positions 1 thru 6, the transmit and receive frequency will be that which is stored in the selected position. To select operating channel, refer to Figure 2-5 and perform the following steps:

(1) Position PWR switch (5) to up (ON) position and verify PWR indicator is on.

(2) Position SCAN switch (4) to OFF position.

(3) Position channel selector switch (3) to desired channel.

- (4) Press and hold READ push-button (6) and ensure correct frequency is displayed on the frequency display (1).

2-9. LOS Operations

Line-of-sight (LOS) operations are used when no obstacles are in the RF path.

NOTE

When operating on the ground, the curvature of the earth or obstacles limits the operating range. To operate around obstacles or extend the range use relay or satellite operations as described in paragraphs 2-10 or 2-11, respectively.

To set up and operate the Radio Sets for LOS operations, connect the Radio as shown in Figure 2-6 and described in paragraph 2-6, then perform the following procedures. Refer to Figure 2-7 for switch locations.

- a. Set SCAN switch (13) to OFF.
- b. Set BEACON switch (5) to NORM.
- c. Set PWR switch (15) to up (on) and verify PWR indicator is on

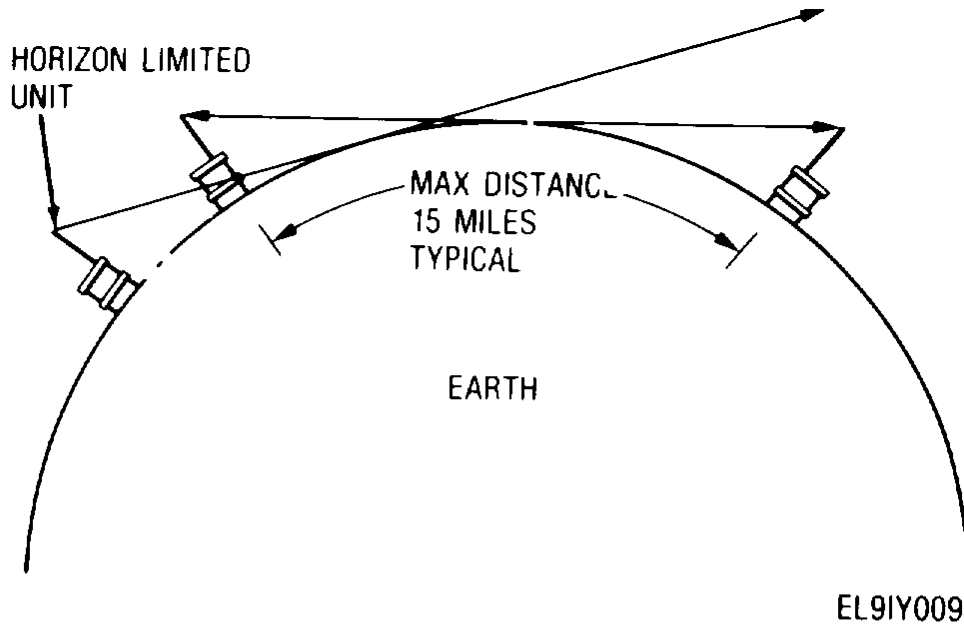
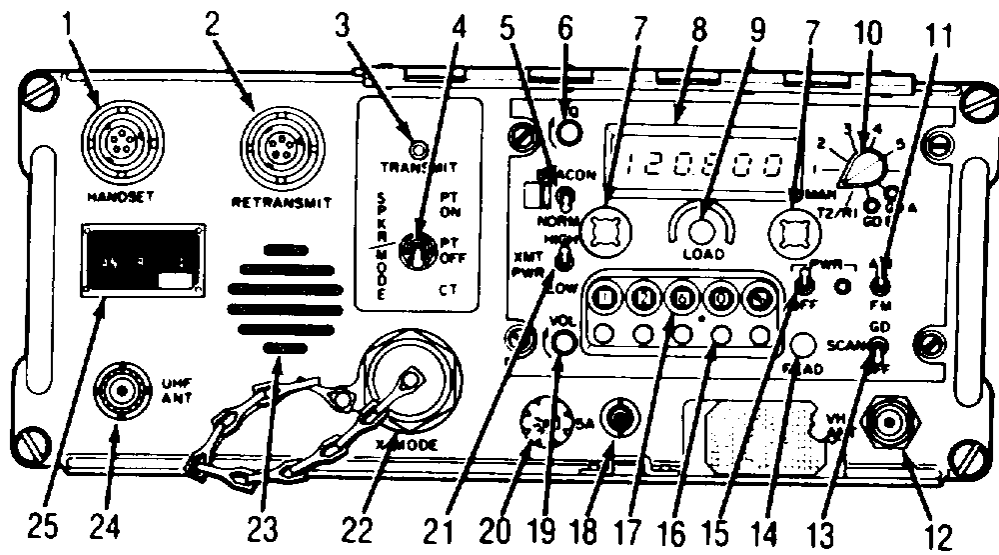

Figure 2-6. LOS Operations Diagram



EL91Y011

Figure 2-7. Operating Controls

- d. If frequencies have been stored, position function selector (10) to channel containing communication link frequency, then press READ (14) push-button and verify frequency. If frequencies have not been stored, load the frequency or use manual selection as per paragraph 2-8.
- e. Set AM/FM switch (11) to position required for modulation mode of communication link.
- f. Set SPEAKER/MODE switch (4) to PT ON position for use of speaker and handset or to PT OFF for use of handset only
- g. Set SQ control (6) fully CCW, adjust VOL control (19) until noise level is heard in handset or on speaker, then slowly turn SQ control (6) CW until noise is not heard.

WARNING

When transmitting with the AN/URC-101 or AN/URC-104, maintain a distance of 16 inches from the antenna tip. When transmitting with the AN/URC-100, maintain a distance of at least 4 inches from the antenna tip. Failure to do so may result in RF burns or eye damage.

- h. To transmit. press handset PTT and transmit message.
- i. To receive, release handset PTT push-button.
- j. To activate and control the scan mode. follow the procedures in paragraph 2-13.

2-10. Relay Operation

Relay operations are used when two or more radios in the same communications link are operating on different frequencies to extend the range, or to operate around obstacles. Either two or four different frequencies may be used. To set up and operate in this configuration, refer to Figures 2-7 and 2-8 and perform the following procedures.

NOTE

The Radio Sets must be at least 50 feet apart unless there is a metal shield between them. Failure to maintain this distance may result in improper operation.

- a. Select and store the assigned frequencies in the desired channels or if T2/R1 is used, the receive frequency must be stored in channel 1 and the transmit frequency in channel 2. Refer to paragraph 2-8 for procedures.

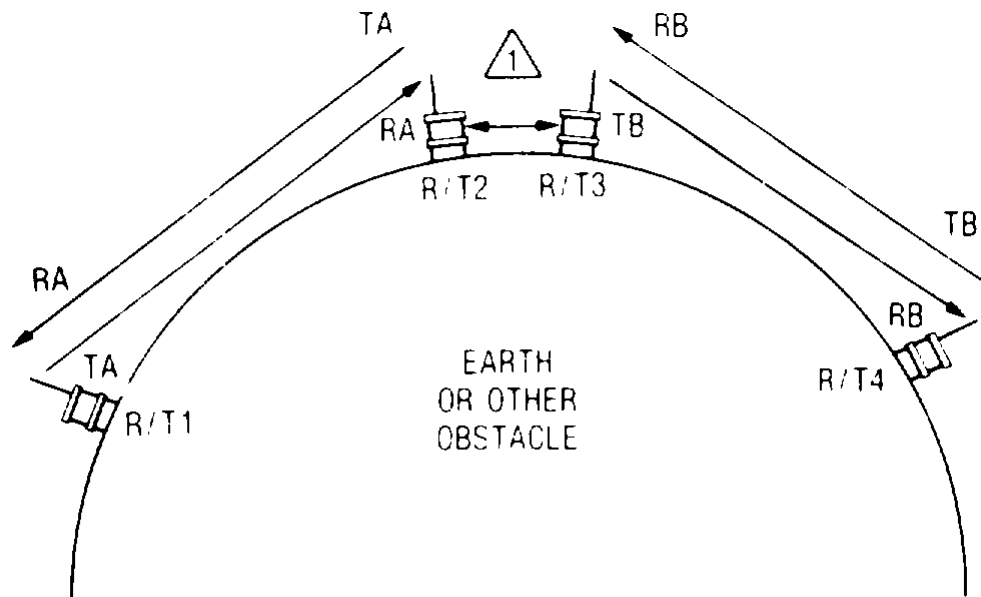

△ 1 RETRANSMIT INTERCONNECTION CABLE

EL9IY010

Figure 2-8. Relay Operations Diagram

NOTE

The transmit and receive frequencies of R/T2 and R/T3 must be separated by at least 2 MHz. Failure to do so may result in improper operation.

NOTE

- **R/T2 and R/T3 receive frequencies must be different**
- **R/T2 and R/T3 transmit frequencies must be different**

- b.** Configure R/T1 and R/T2 for LOS operations and R/T3 and R/T4 for LOS operations.
- c.** Ensure R/T2 and R/T3 PWR switches (15) are in OFF position.
- d.** Connect cable 30-P09976V001 or equivalent between R/T2 and R/T3 RETRANSMIT connectors (2).
- e.** On all radios, set the switches as follows:

SCAN (13)	OFF
BEACON/NORM (5)	NORM
SQ (6)	fully CCW
Function selector (10)	T2/R1
AM/FM (11)	As directed for mission

SPKR/MODE (4)

PT for plain text and speaker use

PT OFF for plain text and handset use

CT for use with COMSEC equipment

NOTE

Squelch control circuits of the receiving unit are used to select transmit mode of the other unit. Thus, if either R/T2 or R/T3 squelch is misadjusted, the radios may not function properly.

f. Adjust the squelch of R/T2 and R/T3 one at a time as follows:

(1) Set PWR switch (15) to up (on)

(2) Position VOL control (19) to approximately three-quarters full CW.

(3) Slowly adjust SO control (6) until noise is barely turned off.

(4) After both squelch controls have been adjusted, set PWR switch (15) to OFF.

- g. Set all Radio Sets' PWR switches (15) to up (on)
- h. Check out communications link by establishing communications between R/T1 and R/T4 via R/ T2 and R/T3.

NOTE

- **If R/T3 TRANSMIT indicator (3) does not illuminate when R/T1 is transmitting or remains illuminated when R/T1 is not transmitting, R/T2 squelch is not adjusted right.**
 - **If R/T2 TRANSMIT indicator (3) does not illuminate when R/T4 is transmitting or remains illuminated when R/T4 is not transmitting, R/T3 squelch is not adjusted right.**
- i. If the communication link is secured, refer to paragraph 2-12 and reconfigure R/T1 and R/T4.
 - j. If the communications link is not secured, the equipment is ready for use

2-11. Satellite Operation

Satellite operations are used for extremely long ranges or when equipments are not available for relay operations. The AN/URC-101 or AN/URC-104, along with at least a 6 dB gain directional antenna, must be used for this configuration. To setup and operate via satellite, refer to Figures 2-7 and 2-9 and perform the following steps:

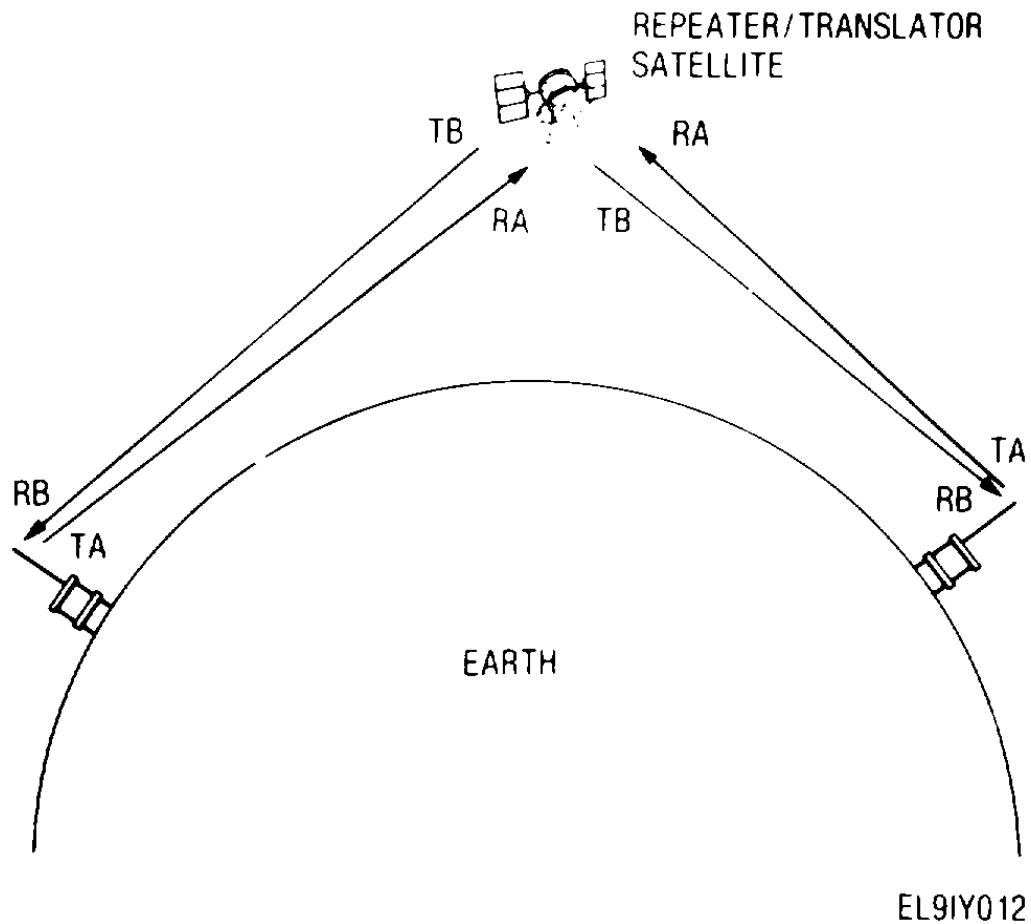

Figure 2-9. Satellite Operations Diagram

NOTE

The selected satellite frequency channels must be in increments of 25 kHz.

- a. Set BEACON switch (5) to NORM.
- b. Set SCAN switch (13) to OFF.

- c. Set PWR switch (15) to up (on).
- d. Using procedures in paragraph 2-6, store assigned receive frequency in channel 1 and transmit frequency in channel 2.

NOTE

The higher frequency must be stored in channel 2.

- e. Position function selector switch (10) to T2/R1 position.
- f. Press READ switch (14) to verify receive frequency on the frequency display (8).
- g. Press READ switch (14) and PTT to verify transmit frequency.
- h. Connect satellite antenna to UHF (24) antenna connector.
- i. Set AM/FM switch (11) to FM.
- j. Set XMT PWR switch (21) to HIGH.
- k. Set SPKR/MODE switch (4) to PT ON for speaker use or to PT OFF for handset use.
- l. Turn SQ control (6) fully CCW.
- m. Turn VOL control (19) CW from fully CCW position until noise is heard in handset (or speaker if on).

2-11. Satellite Operation (cont)

- n. Turn SQ control (6) CW until noise is just turned off
- o. Point antenna in direction of satellite

NOTE

If communications link is secured, refer to paragraph 2-12. If not proceed to next step.

- p. Press PTT to transmit and release PTT to receive.

2-12. COMSEC Operations

COMSEC operations are used when the communications link is secured with KY-57, KY-58, or KY-65 equipment. These units can be used with any configuration described in paragraphs 2-9 thru 2-11. When using the COMSEC equipment, it must be connected to the radios that would normally have the handset connected instead of those used for relay or retransmit configurations. Setup and operating procedures for radios are described below; however, COMSEC equipment switch positions and standard operating procedures must be obtained from their respective operating manuals. To setup and operate in this configuration, refer to Figures 2-7 and 2- 10 and perform the following procedures:

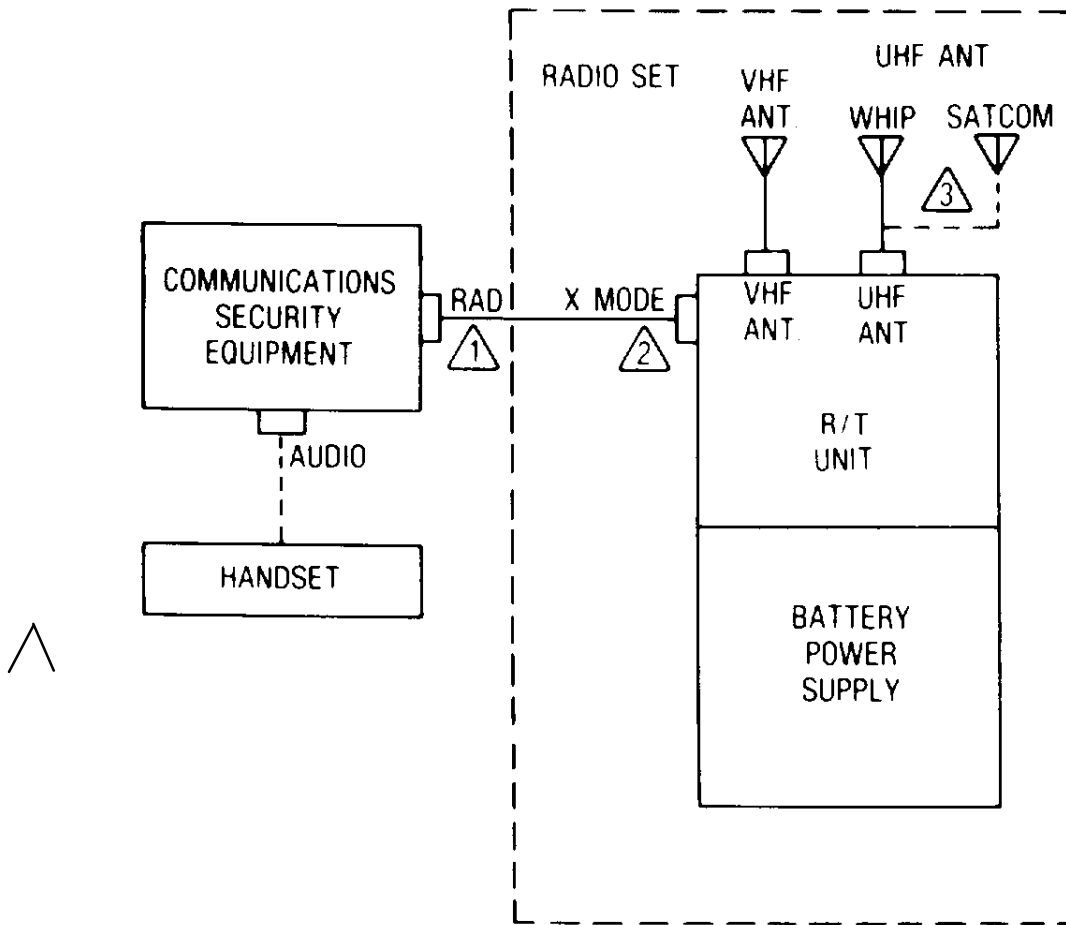

- NOTES
- 1 CABLE SUPPLIED WITH SECURED COMMUNICATIONS EQUIPMENT
 - 2 CONNECTOR IS LABELED TEST/ REMOTE ON AN/URC-100 AND X MODE ON AN/URC-101 AND AN/URC-104
 - 3 SATCOM ANTENNA FOR SATELLITE OPERATIONS

EL9IYO13

Figure 2-10. COMSEC Operations Diagram

12-12. COMSEC Operations (cont)

- a. Set Radio PWR (15) and COMSEC equipment power switches to OFF
- b. Connect the interface cable as shown in Figure 2-10

NOTE

- **The AN/URC-100 KY-57 Interface connector is labeled TEST/REMOTE. The AN/URC-101 and AN/URC-104 connectors are labeled X MODE.**
 - **The interface cable is supplied with the COMSEC equipment.**
- c. Connect the handset to Radio HANDSET connector (1) until squelch is set
 - d. Set Radio function selector (10) to the desired channel. If frequency has not been loaded, refer to paragraph 2-8 and load operating frequencies before proceeding
 - e. Set Radio AM/FM switch (11) to FM
 - f. Set the following Radio switches as shown below:

BEACON/NORM (5)	NORM
SCAN (13)	OFF

XMT PWR (21)	HIGH
SPKR/MODE (4)	PT ON (for speaker) PT OFF (for handset)
VOL (19)	Fully CCW
SQ (6)	Fully CCW

- g. Set Radio PWR (15) and COMSEC equipment to ON.
- h. Turn Radio VOL control (19) CW until noise is heard in speaker (or handset).
- i. Slowly turn Radio SO control (6) CW until noise is just turned off.
- j. Set SPKR/MODE switch (4) to CT.
- k. Transfer handset to COMSEC equipment handset connector.
- l. Refer to COMSEC equipment operator's manual for further instructions.

12-13. Scanning Operation

The scanning operation is used when one main channel and two guard channels or either of the guard channels are to be monitored. The scan mode can be used in any configuration, but will scan only when the function selector is in positions 1 through 6. To operate in the scan mode, refer to Figure 2-7 and perform the following procedures:

2-13. Scanning Operation (cont)

- a. If frequencies have not been stored, refer to paragraph 2-8 for frequency selection and loading.
- b. Set up the equipment for the desired type of communications link.
- c. To scan a main channel and both guard channels, set SCAN switch (13) to GD and function selector switch (10) to desired main channel.
- d. When message is received, note state of GD A and GD B indicators (10).
- e. If either indicator is on and you want to talk with that station, reposition function selector switch (10) to that position and set SCAN switch (13) to OFF. If not, leave SCAN switch in GD position. If neither indicator is on, leave the function selector in main channel.
- f. To reactivate the scan, repeat step c.

2-14. Beacon Operation

The beacon mode is selected when a weeping tone is to be constantly transmitted. To transmit the beacon, refer to Figure 2-7 and set BEACON/NORM switch (5) to BEACON. When beacon is activated, the Radio is in constant transmit mode and cannot receive a message.

2-15. Preparation for Movement

To prepare the Radio for storage or shipment, refer to Figures 2-2 and 2-7 and perform the following:

- a. Set PWR switch (15) to OFF.
- b. Turn antennas ring CCW and lift antennas off of connectors (12 and 24).

CAUTION

Do not twist body of antenna. To do so may result in damage to Radio.

- c. Turn ring of handset connector (1) CCW and remove handset. Slight inward pressure will be necessary to remove handset.
- d. Close hinged cover over control panel.
- e. Open spring loaded latches securing power supply, then separate power supply from R/T unit
- f. Repack as necessary.

2-39/(2-40 blank)

**CHAPTER 3
MAINTENANCE INSTRUCTIONS**

**Section I. TROUBLESHOOTING
PROCEDURES**

Subject	Para.	Page
General.....	3-1	3-1
Symptom Index.....	3-2	3-3
Troubleshooting Procedures.....	3-3	3-4

3-1. General

This section contains instructions to assist you in locating the failed part of the Radio Set. These instructions consist of a symptom index and troubleshooting procedures. The symptom index in Table 3-1 lists the failure symptoms you may find while performing your PMCS. The troubleshooting Procedures in Table 3-2 help you find the failed part and repair the Radio Set.

You are permitted to repair your Radio Set by recharging the batteries or by replacing one or more of the following parts:

- handset
- antennas
- power supply
- batteries
- battery insert
- interconnecting cables
- fuses
- edge lamps

To repair your radio set, first refer to the Symptom Index in Table 3-1. Locate the symptom you found while performing your PMCS. Then, look in the right-hand column and note the malfunction number. Turn to the troubleshooting procedures in Table 3-2 and find the malfunction number in the first column. Perform the test and inspection in the second column in the order listed until you find a bad indication. Perform the corrective actions in the order listed until the problem is corrected. Once the Radio Set has been repaired, perform all of your PMCS to ensure the Radio Set is ready for use.

3-2. Symptom Index

The symptom index is in Table 3-1.

Table 3-1. Symptom Index

Symptom	Troubleshooting Procedure Ref
PWR indicator lamp fails to light when PWR switch is in up position.	Malfunction 1
Edge lamp(s) fail to light when READ switch is pressed.	Malfunction 2
Frequency display lamp segments fail to light when READ switch is pressed.	Malfunction 3
TRANSMIT indicator fails to light when handset is keyed.	Malfunction 4
Communications cannot be made with another operating Radio Set.	Malfunction 5
Radio Set fails to operate in relay mode but operates in LOS mode.	Malfunction 6
Radio Set fails to operate during satellite communications.	Malfunction 7
Batteries fail to recharge.	Malfunction 8
Transmission or reception is distorted or degraded during Radio Set operation.	Malfunction 9

3-3. Troubleshooting Procedures

The troubleshooting procedures are in Table 3-2

- a. The table lists the common malfunctions which you may find during the operation or maintenance of the Radio Set or its components.
- b. To use the troubleshooting procedures, locate the malfunction in Table 3-2. Follow the procedures in the order listed. Once the problem has been found, do not perform any more tests in Table 3-2. Establish communications with another radio to ensure all of the problems have been found.
- c. This manual cannot list all malfunctions that may occur, nor all tests or inspections and corrective actions. If a malfunction is not listed or is not corrected by listed corrective actions, notify your supervisor.

WARNING

- **Lethal voltage is present when the power supply ac cable is connected to the power supply and ac outlet. Ensure cable is disconnected before you open the power supply enclosure. Failure to do so may result in personnel injury or death.**

- High RF power is present at the antenna tip when transmitting. Do not key the transmitter when personnel are closer than 4 inches in the low power mode, or 16 inches in the high power (20 W) mode. To do so may result in personnel injury.

CAUTION

Make sure the power supply power cable is disconnected and the R/T PWR switch is turned off before you replace the RIT unit, battery supply, fuses, or the charging cable. Failure to do so may result in equipment damage.

Table 3-2. Troubleshooting Procedures

MALFUNCTION

Test or Inspection

Corrective Action

1. PWR indicator fails to light

Step 1 Turn off PWR switch and check front panel fuse.

If blown, replace fuse. If not, install known-good batteries.

MALFUNCTION

Test or Inspection

Corrective Action

1. PWR indicator fails to light (Cont)

Step 2 Turn on R/T unit PWR switch, then check power indicator

If on, recharge old batteries. If not, turn off R/T unit PWR switch and replace power supply as per paragraph 3-5.

Step 3 Turn on R/T unit PWR switch, then check power indicator

If on, send failed power supply to higher level of maintenance. If not, turn off R/T unit PWR switch, then replace the R/T unit.

Step 4 Turn on R/T unit PWR switch and check power indicators

If on, send old R/T unit to higher level of maintenance. If not, notify your supervisor.

2. Edge lamp(s) fail(s) to light when READ switch is pressed.

Step 1 Install new lamps in holders per paragraph 3-8, then recheck.

If lamps are still not lighted, install new RIT unit.

Step 2 Recheck lamps

If lamps are lighted, send old RIT unit to next higher level of maintenance. If lamps are still not lighted, notify your supervisor.

Table 3-2. Troubleshooting Procedures (Cont)

MALFUNCTION

Test or Inspection

Corrective Action

3. Frequency display lamp segments fail to light when READ switch is pressed.

Turn off R T unit PWR switch, install known-good R/T unit, then retest.

If all segments are lighted, send failed R/T unit to next higher level of maintenance. If not, notify your supervisor.

4. TRANSMIT indicator does not light when handset is keyed.

Sequentially substitute the following components until the TRANSMIT indicator lights. Recheck unit after each component is changed.

Handset

Power Supply

R/T unit

Antenna

If TRANSMIT lamp still does not work properly, notify your supervisor. If substituting one of the components repairs the radio, send the failed component to the next higher level of maintenance.

5. Communications cannot be made with another operating radio set.

Perform tests, inspections and corrective actions as outlined for Malfunction number 4

If Radio Set is repaired, send failed component to next higher level of maintenance. If communications still cannot be made, notify your supervisor.

Table 3-2. Troubleshooting Procedures (Cont)

MALFUNCTION

Test or Inspection

Corrective Action

6. Radio Set fails to operate in relay mode, but operates in LOS mode.

Step 1 Replace retransmit cable, then retest.

If Radio Set works, send cable to next higher level of maintenance.

Step 2 Replace each R/T unit Retest after each replacement.

If Radio Set works, send failed R/T unit to next higher level of maintenance.

If Radio Set still does not work. notify your supervisor.

7. Radio Set fails to operate during satellite communications.

Step 1 Using satellite communication configuration, establish LOS communications with another Radio Set

If communications are made, replace RIT unit. Send failed RIT unit to next higher level of maintenance.

If not, replace RIT unit-to-satellite antenna cable.

Step 2 Repeat step 1 test

If communications are made, send failed RIT unit- to-satellite antenna cable to next higher level of maintenance.

If not, replace satellite antenna.

Step 3 Repeat step 1 test

If communications are made, send failed antenna to next higher level of maintenance.

If not, notify your supervisor.

MALFUNCTION

Test or Inspection

Corrective Action

8. Batteries fail to recharge.

WARNING

Lethal voltages are exposed when battery insert is removed and power supply ac power cable is connected to ac outlet. Failure to disconnect the power cable from the outlet may result in injury or death.

NOTE

Only the nickel cadmium batteries (MA6982-3A or equivalent) can be charged.

Step 1 Disconnect power cable from power source

Step 2 If power supply is attached to the R/T unit remove per paragraph 3-5

Step 3 Remove battery insert from power supply as per paragraph 3-7 steps a and b

Step 4 Inspect power supply fuse shown in Figure 3-3

If blown, replace fuse. Reassemble unit, then attempt to recharge batteries as per paragraph 3-6. If fuse is not blown, replace batteries per paragraph 3-7, then reassemble battery supply.

Table 3-2. Troubleshooting Procedures (Cont)

MALFUNCTION

Test or Inspection

Corrective Action

8. Batteries fail to recharge (Cont)

Step 5 Attempt to recharge batteries per paragraph 3-6
If batteries charge, dispose of failed batteries.
If not, replace charging cable.

Step 6 Attempt to recharge batteries per paragraph 3-6
If batteries charge, send failed cable to higher level of maintenance.
If not, replace power supply.

Step 7 Attempt to recharge batteries per paragraph 3-6
If batteries will not charge, notify your supervisor.

9. Equipment operates in a distorted or degraded condition.

Perform the tests, inspections and corrective actions outlined in malfunction number 4
Repair or replace as necessary.

Section II. MAINTENANCE PROCEDURES

Subject	Para.	Page
General.....	3-4	3-11
Battery Power Supply Removal/Replacement.....	3-5	3-11
Battery Charging Procedure	3-6	3-14
Battery Removal/Replacement.....	3-7	3-16
Edge Lamp Removal/Replacement.....	3-8	3-18

3-4. General

This section contains the maintenance operations required to service your Radio Set. Perform these procedures when referenced in Section I.

3-5. Battery Power Supply Removal/ Replacement

WARNING

The snap fasteners shown in figure 3-1 are spring loaded. To avoid pinched fingers, use care when snapping or unsnapping fasteners.

To remove or install the battery power supply, refer to Figure 3-1. position R/T unit power switch to OFF and perform the following steps.

a. Removal

- (1) Position Radio Set in upright position.
- (2) Lift up on each snap fastener lever until it snaps open.
- (3) Lift up on each snap fastener lever and pull away from the catch on the R/T unit.
- (4) Lift up on R/T unit while gently shaking until R/T unit separates from battery power supply.

b. Installation

- (1) Position battery power supply as shown in Figure 3-1
- (2) Ensure pull ring is flat against top of insert as shown
- (3) Align R/T unit directly over battery power supply with bottom toward you.
- (4) Slowly lower the R/T unit onto the battery power supply
- (5) Gently press down on the R/T unit handles until the power plugs are fully seated
- (6) Position snap fastener latches over catches on R/T unit

- (7) Press down on snap fastener levers until levers snap into place.

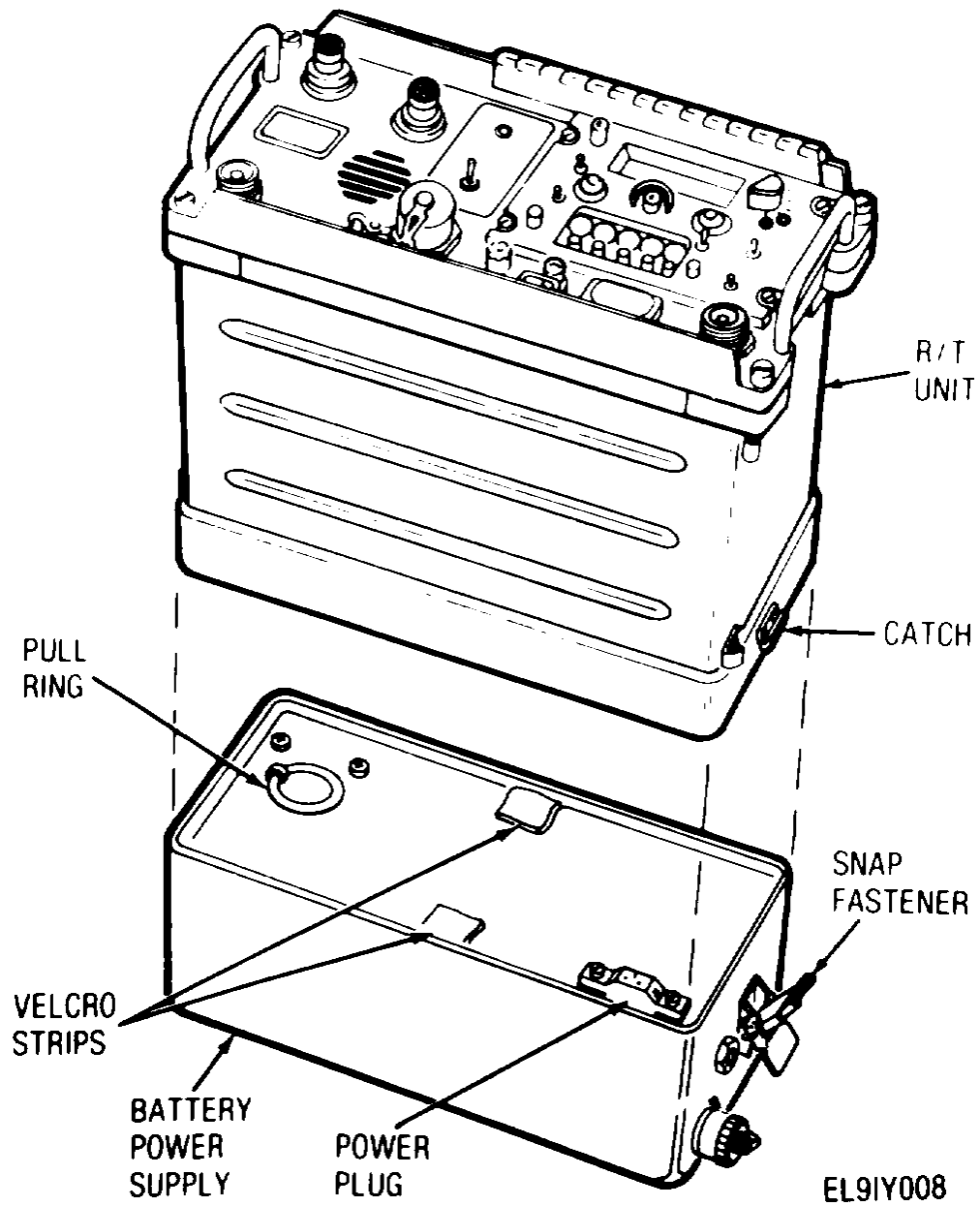

Figure 3-1. Battery Power Supply Removal Installation Diagram

3-6 Battery Charging Procedure

The battery power supply batteries can be recharged to a certain level without removing them from the battery power supply case. Either a 115 Vac (105 to 125V) or +28 V (22 to 30V) source can be used to recharge the batteries. The battery supply can be either attached to or removed from the R/T unit while the batteries are charging. To recharge the batteries, proceed as follows.

- a. Connect the battery case power input terminal to a source of charging power as shown in Figure 3-2. Use the cable supplied with the battery power supply for this purpose.

NOTE

The R/T unit will not operate properly when charging the supply from a 115 Vac source. The R/T unit will operate properly when charging from a +28 V source.

- b. Allow the battery supply to charge to the proper level. When using the 115 Vac source, the batteries will be charged to 70 percent full charge in 40 hours. When using the 28 V source, the batteries will be charged to 80 percent full charge in 16 hours.

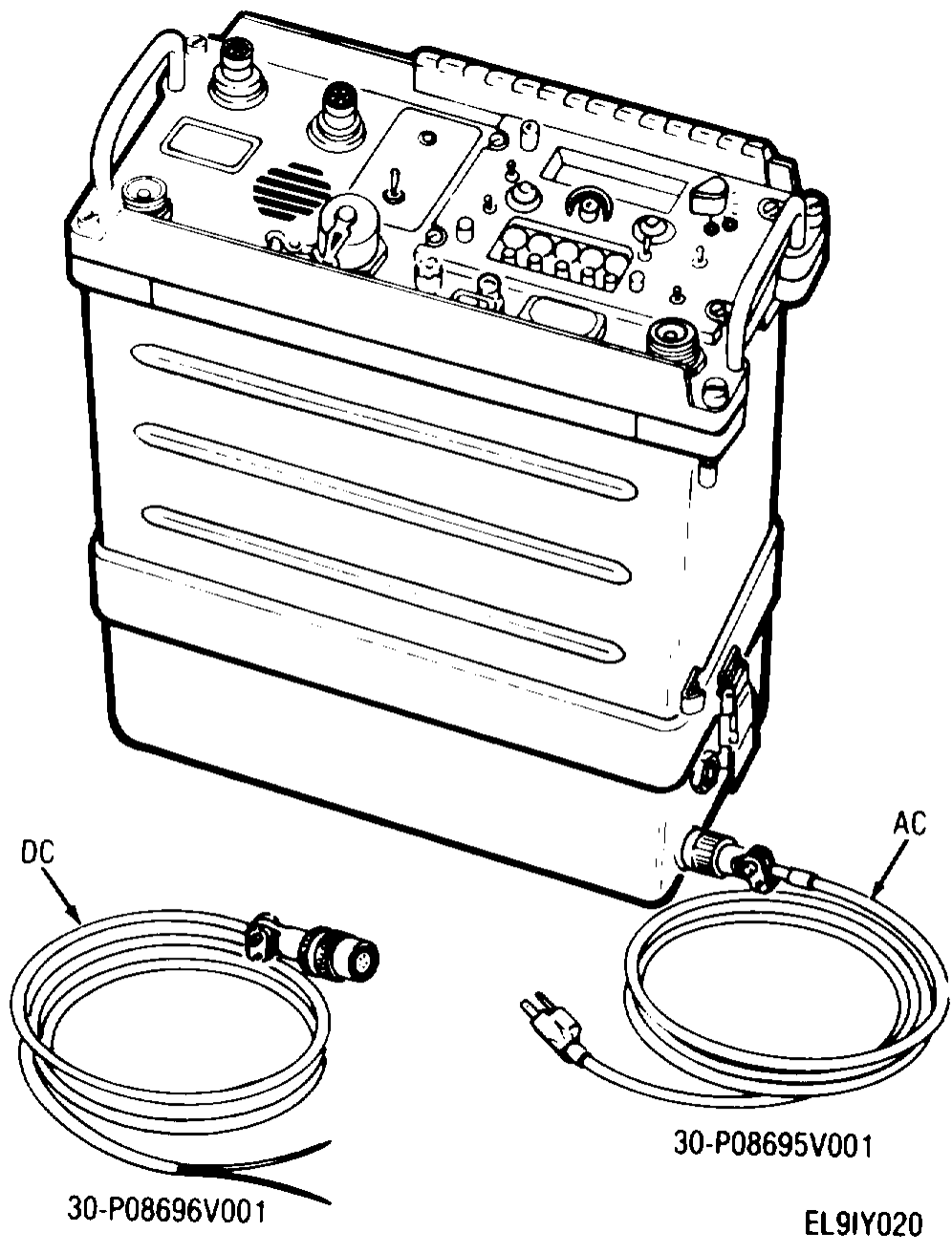

Figure 3-2. Battery Power Supply Charging Setup

NOTE

Higher charge levels can be obtained by keeping the batteries and case at +70° (+220C) or below.

3-7. Battery Removal/Replacement

Figure 3-3 shows how the batteries are mounted in the battery power supply. To remove or replace the batteries, proceed as follows.

- a.** Pull the two Velcro strips that hold the battery insert in the battery case upward and outward until they are fully separated.
- b.** Pull the pull ring on the battery insert and remove the insert from inside the case.
- c.** Pull each battery (there are two) straight out from the insert so that they slide free from their connectors.
- d.** To replace a battery, line up the plugs on the battery and battery insert and push the battery fully into the insert.
- e.** Carefully place the battery insert into the battery case and fasten the two Velcro strips.

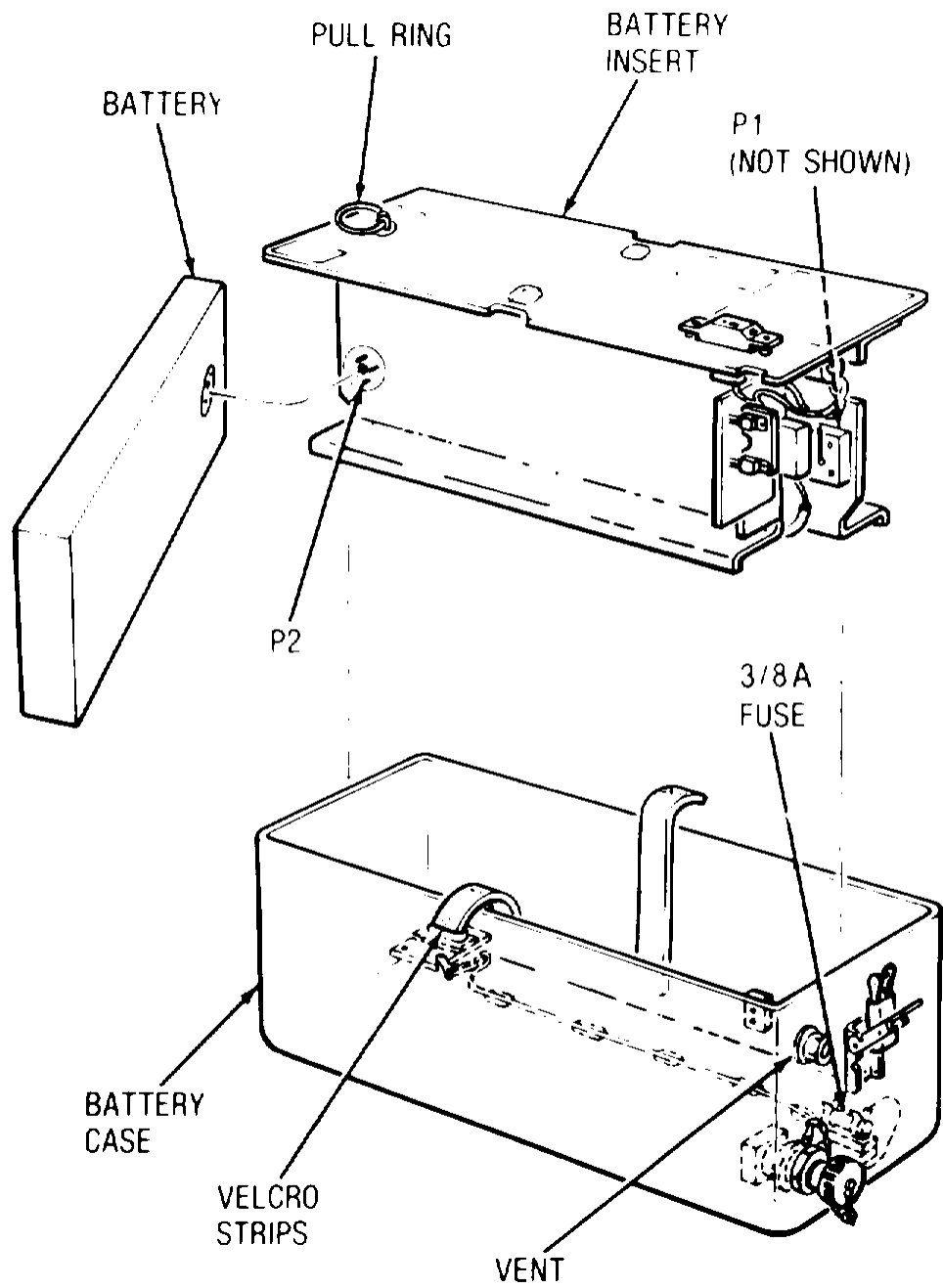

EL91Y019

Figure 3-3 Battery Replacement Diagram

3-8. Edge Lamp Removal/Replacement

a. Removal

- (1)** Position the Radio Set in upright position.
- (2)** Unscrew lampholder (Figure 2-7, item 7) from socket.
- (3)** Use fingernails to grasp the lamp base and remove lamp from holder.

b. Replacement

- (1)** Place lamp in holder.
- (2)** Screw lampholder into socket.

**APPENDIX A
REFERENCES**

A-1. Scope

This appendix lists all forms, manuals and miscellaneous publications referenced in this manual.

A-2. Forms

Recommended Changes to Publications and Blank Forms.....	DA Form 2028
Quality Deficiency Report.....	SF 368
Equipment Log.....	DA Form 2408-9

A-3. Manuals

The Army Maintenance Management System (TAMMS)	DA Pam 738-750
Battery Power Supply Operation and Maintenance Manual	

A-1/(A-2 blank)

**APPENDIX B
COMPONENTS OF END ITEM LIST**

Section I. INTRODUCTION

B-1. Scope

This appendix lists components of end item and basic issue items for the Radio Set to help you inventory items required for safe and efficient operation

B-2. General

The Components of End Item List is divided into the following sections:

B-1

B-2. General (cont)

- a. Section II. Components of End Item.** This listing is for informational purposes only, and is not authority to requisition replacements. These items are part of the end item, but are removed and separately packaged for transportation or shipment. As part of the end item, these items must be with the end item whenever it is issued or transferred between property accounts. Illustrations are furnished to assist you in identifying the items.
- b. Section III. Basic Issue Items.** These are the minimum essential items required to place the Radio Set in operation, to operate it, and to perform emergency repairs. Although separately packaged and shipped, BII must be with the Radio Set during operation and whenever it is transferred between property accounts. The illustrations will assist you with hard-to-identify items. This manual is your authority to request/requisition replacement BII, based on TOE/MTOE authorization of the end item.

B-3. Explanation of Columns

The following provides an explanation of columns found in the tabular listings.

- a. **Column (1)-Illustration Number (Illus Number).** This column indicates the number of the illustration in which the item is shown
- b. **Column (2)-National Stock Number.** Indicates the National stock number assigned to the item and will be used for requisitioning purposes
- c. **Column (3)-Description.** Indicates the Federal item name and, if required, a minimum description to identify and locate the item. The last line for each item indicates the FSCM (in parentheses) followed by the part number.
- d. **Column (4)-Unit of Measure (U/M).** Indicates the measure used in performing the actual operational/maintenance function. This measure is expressed by a two-character alphabetical abbreviation (e g ea in. pr)
- e. **Column (5)-Quantity required (Qty rqr).** Indicates the quantity of the item authorized to be used with/on the equipment

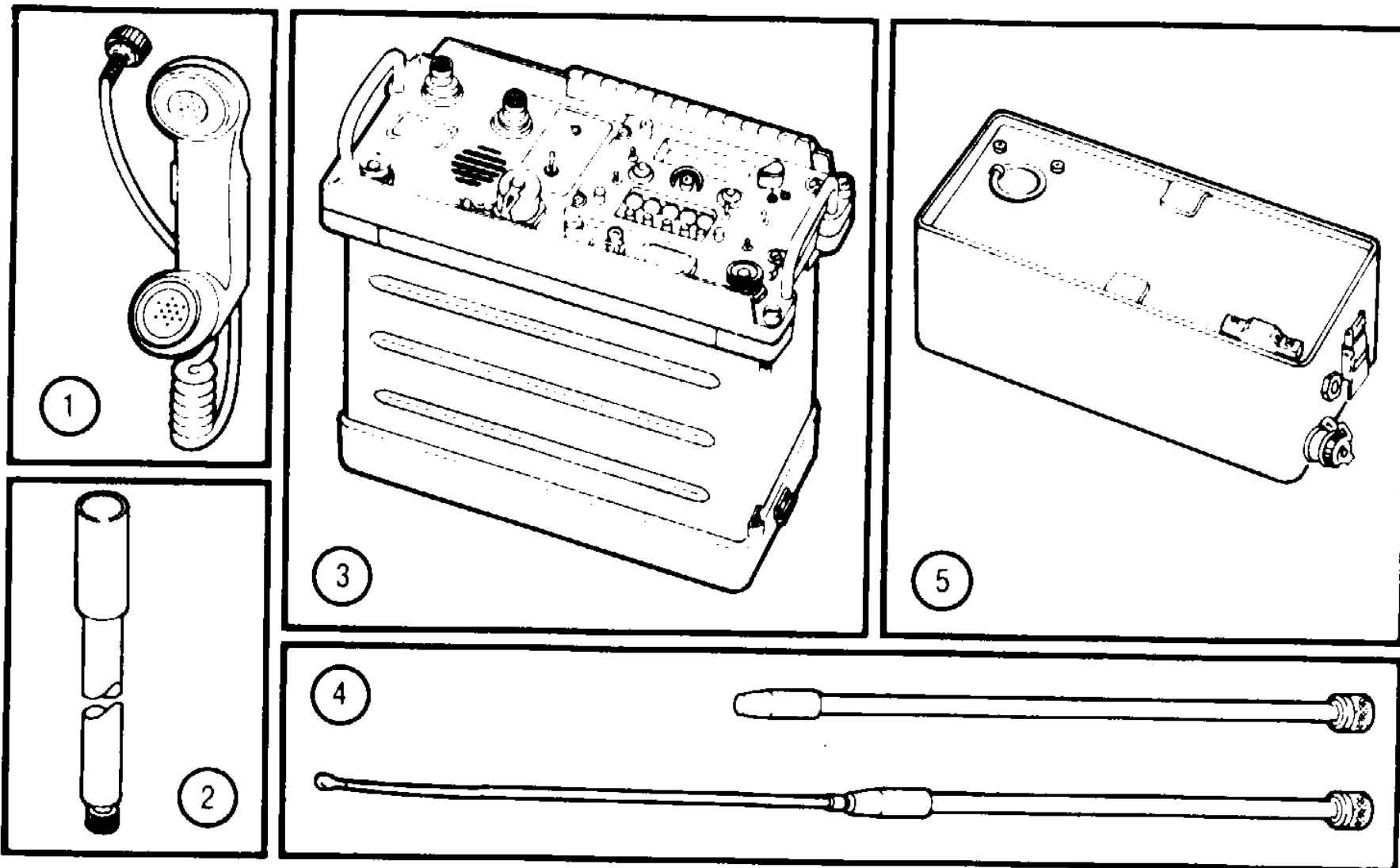

Radio Sets AN/URC-100, AN/URC-101 and AN/URC 104.

EL91YO14

Section II.
Components of End Item AN/URC-1 00 Radio Set

(1) Illus No	(2) National Stock No	(3) Description FSCM and Part No.	Usable on Code	(4) U/M	(5) Qty Rqr
1	5965-00-069-8886	Handset, H-189/GR, Model PTHS-110 (94990) Part Number 01-P04535L001		EA	1
2		Antenna. (Nomenclature has been requested) UHF. Model PTUA-110 (94990), Part Number 85-P04534L001		EA	1
3		Receiver/Transmitter or R/T (94990) Part Number 01-P04539L005		EA	1
4		Antenna. (Nomenclature has been requested) VHF. Model PTVA-1 10 (94990) Part Number 85-P04533L001		EA	1
5		Power Supply, (Nomenclature has been requested) Model PTMG-120 (94990) Part Number 01 -P08693V001 (ac and dc charging cables not shown)		EA	1
6	6135-00-926-8322	Battery, BA-4386 (non-rechargeable) (not shown)		EA	2

Section II - continued.
Components of End Item AN/URC-1 00 Radio Set

(1) Illus No	(2) National Stock No	(3) Description FSCM and Part No.	Usable on Code	(4) U/M	(5) Qty Rqr
1	5965-00-069-8886	Handset, H- I89/GR, Model PTHS-1 10 (94990) Part Number 01-P04535L001		EA	1
2		Antenna, UHF, Model PTUA-110 (94990) Part Number 85-P04534L001		EA	1
3		Receiver/Transmitter or R/T (94990) Part Number 01-P04539L007		EA	1
4		Antenna, VHF, Model PTVA-1 10 (94990) Part Number 85-P04533L001		EA	1
5		Power Supply, Model PTMG-120 (94990) Part Number 01 -P08693V001 (ac and dc charging cables not shown)		EA	1
6	6135-00-926-8322	Battery, BA-4386 (non-rechargeable) (not shown)		EA	2

Section II - continued.
Components of End Item AN/URC-1 00 Radio Set

(1) Illus No	(2) National Stock No	(3) Description FSCM and Part No.	Usable on Code	(4) U/M	(5) Qty Rqr
1	5965-00-069-8886	Handset, H-189/GR, Model PTHS-110 (94990) Part Number 01-P04535L001		EA	1
2		Antenna, UHF, Model PTUA-110 (94990) Part Number 85-P04534L001		EA	1
3		Receiver/Transmitter or R/T (94990) Part Number 01 -P04539L008		EA	1
4		Antenna, VHF, Model PTVA-120 (94990) Part Number 85-P09268W001		EA	1
5		Power Supply, Model PTMG-120 (94990) Part Number 01-P08693V001 (ac and dc charging cables not shown)		EA	1
6	6135-00-926-8322	Battery, BA-4386 (non-rechargeable) (not shown)		EA	2

Section III. BASIC ISSUE ITEMS

One copy of TM 11-5895-1195-10 (Operators Manual) is supplied with each shipped Radio Set There are no other Basic Issue Items.

**APPENDIX C
ADDITIONAL AUTHORIZATION LIST**

Section I. INTRODUCTION

C-1. Scope

This appendix lists additional items you are authorized for the support of the Radio Sets

C-2. General

This lists identifies items that do not have to accompany the Radio Sets and that do not have to be turned in with it. These items are all authorized to you by CTA, MTOE, TDA, or JTA.

**APPENDIX D
EXPENDABLE SUPPLIES AND MATERIALS LIST**

Section I. INTRODUCTION

D-1. Scope

This appendix lists expendable supplies and materials you will need to operate and maintain the Radio Set. These items are authorized to you by CTA 50-970, Expendable Items (Except Medical, Class V, Repair Parts, and Heraldic Items)

D-2. Explanation of Columns

- a. **Column (1) -Item Number.** This number is assigned to the entry in the listing and is referenced in the narrative instructions to identify the material (e.g., "Use cleaning compound, item 5, App. D").

b. **Column (2) - Level.** This column identifies the lowest level of maintenance that requires the listed item.

C-Operator/Crew

O-Organizational Maintenance

F-Direct Support Maintenance

H-General Support Maintenance

c. **Column (3) - National Stock Number.** This is the National stock number assigned to the item. use it to request or requisition the item.

d. **Column (4) - Description.** Indicates the Federal item name and, if required, a description to identify the item The last line for each item indicates the Federal Supply Code for Manufacturer (FSCM) in parentheses followed by the part number.

e. **Column (5) - Unit of Measure (U/M).** Indicates the measure used in performing the actual maintenance function. This measure is expressed by a two-character alphabetical abbreviation (e.g., ea, in., pr). If the unit of measure differs from the unit of issue, requisition the lowest unit of issue that will satisfy your requirements.

Section II. EXPENDABLE SUPPLIES AND MATERIALS LIST

(1) ITEM NUMBER	(2) LEVEL	(3) NATIONAL STOCK NUMBER	(4) DESCRIPTION	(5) U/M
1	C	7920-00-292-9204	Cloth. cleaning MIL-C-85043A	EA

By Order of the Secretaries of the Army, the Navy and the Air Force:

JOHN A. WICKHAM JR.
General, United States Army
Chief of Staff

Official:

ROBERT M. JOYCE
Major General, United States Army
The Adjutant General

G.H. SCHICK, JR.
Rear Admiral, United States Navy
Commander, Naval Electronic
Systems Command

Official:

JAMES P. MULLINS
General, USAF, Commander, Air Force
Logistics Command

CHARLES A. GABRIEL
General, USAF
Chief of Staff

Distribution:
To be distributed in accordance with special list.

GPO: 1992 O - 311-831 (44209)

RECOMMENDED CHANGES TO EQUIPMENT TECHNICAL PUBLICATIONS



THEN... JOT DOWN THE DOPE ABOUT IT ON THIS FORM, CAREFULLY TEAR IT OUT, FOLD IT AND DROP IT IN THE MAIL!

SOMETHING WRONG WITH THIS PUBLICATION?

FROM: (PRINT YOUR UNIT'S COMPLETE ADDRESS)

DATE SENT

PUBLICATION NUMBER

PUBLICATION DATE

PUBLICATION TITLE

BE EXACT... PIN-POINT WHERE IT IS

PAGE NO.

PARA-GRAPH

FIGURE NO.

TABLE NO.

IN THIS SPACE TELL WHAT IS WRONG AND WHAT SHOULD BE DONE ABOUT IT:

TEAR ALONG PERFORATED LINE

PRINTED NAME, GRADE OR TITLE, AND TELEPHONE NUMBER

SIGN HERE:

DA FORM 2028-2
1 JUL 79

PREVIOUS EDITIONS ARE OBSOLETE.

P.S.—IF YOUR OUTFIT WANTS TO KNOW ABOUT YOUR RECOMMENDATION MAKE A CARBON COPY OF THIS AND GIVE IT TO YOUR HEADQUARTERS.

PIN: 056007-000